

Data-Over-Cable Service Interface Specifications

eDOCSIS™ Specification

CM-SP-eDOCSIS-I03-040804

ISSUED

Notice

This specification is a cooperative effort undertaken at the direction of Cable Television Laboratories, Inc. (CableLabs®) for the benefit of the cable industry. Neither CableLabs, nor any other entity participating in the creation of this document, is responsible for any liability of any nature whatsoever resulting from or arising out of use or reliance upon this document by any party. This document is furnished on an AS-IS basis and neither CableLabs, nor other participating entity, provides any representation or warranty, express or implied, regarding its accuracy, completeness, or fitness for a particular purpose.

© Copyright 2003-2004 Cable Television Laboratories, Inc.
All rights reserved.

Document Status Sheet

Document Control Number:	CM-SP-eDOCSIS-I03-040804			
Document Title:	Data-Over-Cable Service Interface Specifications eDOCSIS™ Specification			
Revision History:	I01 - Issued March 12, 2003			
	I02 - Issued November 17, 2003			
	I03 - Issued August 4, 2004			
Date:	August 4, 2004			
Status:	Work in Progress	Draft	Issued	Closed
Distribution Restrictions:	Author Only	CL/Member	CL/Member/Vendor	Public

Key to Document Status Codes:

- Work in Progress** An incomplete document, designed to guide discussion and generate feedback, that may include several alternative requirements for consideration.
- Draft** A document in specification format considered largely complete, but lacking review by Members and vendors. Drafts are susceptible to substantial change during the review process.
- Issued** A stable document, which has undergone rigorous member and vendor review and is suitable for product design and development, cross-vendor interoperability, and for certification testing.
- Closed** A static document, reviewed, tested, validated, and closed to further engineering change requests to the specification through CableLabs.

Trademarks:

DOCSIS®, eDOCSIS™, PacketCable™, CableHome™, CableOffice™, OpenCable™, CableCARD™, and CableLabs® are trademarks of Cable Television Laboratories, Inc.

Contents

1	INTRODUCTION	1
1.1	Scope.....	1
1.2	Goals	1
1.3	DOCSIS Base Specifications.....	2
1.4	Requirements	2
2	REFERENCES	3
2.1	References (normative)	3
2.2	References (informative)	4
2.3	Reference Acquisition	4
3	GLOSSARY	5
4	ABBREVIATIONS.....	6
5	EMBEDDED DOCSIS CABLE MODEM	7
5.1	Device Interface Reference Model	7
5.2	eDOCSIS Requirements.....	12
5.2.1	General Requirements	12
5.2.2	Interface Requirements	13
5.2.3	Operations Support Requirements	13
5.2.4	DHCP Option 43 Syntax Requirements	17
5.2.5	Testability Requirements	23
5.2.6	Firmware Download.....	29
	ANNEX A SLED MIB DEFINITION	30
	ANNEX B ESAFE MIB DEFINITION	35
	APPENDIX I ACKNOWLEDGEMENTS.....	41
	APPENDIX II REVISION HISTORY	42

Figures

Figure 5-1 - eDOCSIS Reference Model	8
Figure 5-2 - CableHome Home Access eDOCSIS Device Reference Model	8
Figure 5-3 - eCM - ePS Protocol Stacks	9
Figure 5-4 - PacketCable E-MTA (with DOCSIS CM) eDOCSIS Reference Model.....	9
Figure 5-5 - eCM - eMTA Protocol Stacks	10
Figure 5-6 - OpenCable Host 2.0 eDOCSIS Reference Model.....	10
Figure 5-7 - eCM – eSTB Protocol Stacks – OpenCable Host 2.0	11
Figure 5-8 - Embedded Security STB eDOCSIS Reference Model	11
Figure 5-9 - eCM – eSTB Protocol Stacks – Embedded Security STB.....	12
Figure 5-10 - SLED Reference Model.....	24
Figure 5-11 - SLED Packet Loopback Encapsulation	26
Figure 5-12 - SLED Packet Loopback And Generation Sequences	28

Tables

Table 5-1 - eDOCSIS ifTable Interface Designations	14
Table 5-2 - [RFC 2863] ifTable, MIB-Object Details for eDOCSIS Device Interfaces...	15
Table 5-3 - [RFC 2011] ipNetToMedia MIB-Object Details for eDOCSIS Device Interfaces	16
Table 5-4 - dot1dStaticTable Entries for DSG MAC Addresses.....	17
Table 5-5 - DHCP Option 43 Syntax	19
Table 5-6 - Example eDOCSIS Device: E-MTA.....	20
Table 5-7 - Example eDOCSIS Device: DOCSIS 1.1 CableHome/E-PS	21
Table 5-8 - Example eDOCSIS Device: DOCSIS 1.1 Embedded STB.....	22
Table 5-9 - Example eDOCSIS Device Containing DOCSIS 2.0 eCM, eMTA and ePS23	

1 INTRODUCTION

Existing DOCSIS specifications were created for stand-alone cable modems that provide high-speed broadband services using the hybrid-fiber-coaxial cable infrastructure. The emergence of a class of devices that embeds additional functionality with a Cable Modem, such as packet-telephony, home networking and video, has necessitated the creation of this specification to define additional requirements such as interfaces, management and provisioning models. This is necessary to insure that the Cable Modem will function properly and interact properly with the embedded Service/Application Functional Entities (eSAFEs).

1.1 Scope

This specification defines additional features that must be added to a DOCSIS Cable Modem for implementations that embed the Cable Modem with another application, such as a PacketCable MTA.¹

1.2 Goals

The goals for this specification are:

- To preserve functional separation of the DOCSIS cable modem entity from eSAFEs within the eDOCSIS Device, so that existing DOCSIS cable plant integrity, cable modem configuration, management and provisioning security are not compromised.
- To isolate DOCSIS cable modem functionality so that specification compliance can be tested for the eCM component independent of eSAFEs.
- To enable the service provider to enable or disable forwarding traffic between each eSAFE and the eCM within the eDOCSIS Device.
- To maximize compatibility with existing back-office management/provisioning infrastructure so that new services enabled by eDOCSIS devices can be deployed rapidly.
- To architect eDOCSIS devices in such a way as to scale to new services and applications, and to take advantage of technology innovations to achieve low cost and high functionalities.²

¹ Edited per EDOCS-N-03099, 11/11/03, po

² Edited per EDOCS-N-03099, 11/11/03, po

1.3 DOCSIS Base Specifications

There are currently three versions of what are in this document referred to as the DOCSIS Base Specifications. These three versions are commonly referred to as DOCSIS 1.0, DOCSIS 1.1, and DOCSIS 2.0. A list of the document categories in the Data-Over-Cable Service Interface Specifications family is provided below. For updates, please refer to <http://www.cablemodem.com/>.

Designation			Title
DOCSIS 1.0	DOCSIS 1.1	DOCSIS 2.0	
SP-RFI	SP-RFIV1.1	SP-RFIV2.0	Radio Frequency Interface Specification
SP-OSSI	SP-OSSIV1.1	SP-OSSIV2.0	Operations Support System Interface Specification
SP-BPI	SP-BPI+	SP-BPI+	Baseline Privacy Interface Specification
SP-CMCI			Cable Modem to Customer Premises Equipment Interface Specification
SP-CMTS-NSI			Cable Modem Termination System Network Side Interface Specification

1.4 Requirements

Throughout this document, the words that are used to define the significance of particular requirements are capitalized. These words are:

- MUST** This word or the adjective “REQUIRED” means that the item is an absolute requirement of this specification.
- MUST NOT** This phrase means that the item is an absolute prohibition of this specification.
- SHOULD** This word or the adjective “RECOMMENDED” means that there may exist valid reasons in particular circumstances to ignore this item, but the full implications should be understood and the case carefully weighed before choosing a different course.
- SHOULD NOT** This phrase means that there may exist valid reasons in particular circumstances when the listed behavior is acceptable or even useful, but the full implications should be understood and the case carefully weighed before implementing any behavior described with this label.
- MAY** This word or the adjective “OPTIONAL” means that this item is truly optional. One vendor may choose to include the item because a particular marketplace requires it or because it enhances the product, for example; another vendor may omit the same item.

2 REFERENCES

2.1 References (normative)

In order to claim compliance with this specification, it is necessary to conform to the following standards and other works as indicated, in addition to the other requirements of this specification. Notwithstanding, intellectual property rights may be required to use or implement such normative references.

- [DOCSIS-CMCI] DOCSIS Cable Modem to Customer Premise Equipment Interface Specification, SP-CMCI-I09-030730, July 30, 2003, CableLabs
- [RFI 1.0] ANSI/SCTE 22-1 2002: DOCSIS 1.0 Radio Frequency Interface, www.scte.org
- [RFI 1.1] DOCSIS Radio Frequency Interface Specification, SP-RFIV1.1-I10-030730, July 30, 2003, CableLabs
- [RFI 2.0] DOCSIS Radio Frequency Interface Specification, CM-SP-RFIV2.0-I05-040804, August 4, 2004, CableLabs
- [OSSI 1.0] ANSI/SCTE 22-3 2002: DOCSIS 1.0 Operations Support System Interface, www.scte.org
- [OSSI 1.1] DOCSIS Operations Support System Interface Specification, SP-OSSIV1.1-I07-030730, July 30, 2003, CableLabs
- [OSSI 2.0] DOCSIS Operations Support System Interface Specification, CM-SP-OSSIV2.0-I05-040804, August 4, 2004, CableLabs
- [RFC 1493] IETF RFC 1493, Definitions of Managed Objects for Bridges, E. Decker, P. Langille, A. Rijsinghani & K. McCloghrie, July 1993
- [RFC 2011] IETF RFC 2011, SNMPv2 Management Information Base for the Internet Protocol using SMIV2, K. McCloghrie, November 1996
- [RFC 2863] IETF RFC 2863, The Interfaces Group MIB, K. McCloghrie, F. Kastenholz, June 2000
- [RFC 2131] IETF RFC 2131, Dynamic Host Configuration Protocol, Droms, R., March 1997.
- [RFC 2132] IETF RFC 2132, DHCP Options and BOOTP Vendor Extensions, Alexander, S., and R. Droms, March 1997.
- [RFC 3396] IETF RFC 3396, Encoding Long Options in the Dynamic Host Configuration Protocol (DHCPv4), Lemon, T., and S. Cheshire, November, 2002³
- [RFC 791] IETF STD5, RFC 791, Internet Protocol, J. Postel, September 1981.
- [RFC 768] IETF STD6, RFC 768, User Datagram Protogram, J. Postel, September, 1980.

³ Edited per EDOCS-N-03084/ 11/11/03, po

- [DSG] DOCSIS Set-Top Gateway (DSG) Specification, CM-SP-DSG-I02-040804, August 4, 2004, CableLabs.⁴
- [OC2] OpenCable Common Download Specification, OC-SP-CD-IF-I07-040402, April 2, 2004, CableLabs.⁵
- [BPI+] DOCSIS Baseline Privacy Plus Interface Specification, SP-BPI+-I11-040407, April 7, 2004, CableLabs.⁶

2.2 References (informative)

- [CH1.0] CableHome 1.0 Specification, CH-SP-CH1.0-I05-030801, CableLabs, August 1, 2003, www.cablelabs.com/projects/cablehome
- [PC10-MTA] PacketCable MTA Device Provisioning Specification, PKT-SP-PROV-I10-040730, CableLabs, July 30, 2004.
- [PC10-MIB] PacketCable MIBs Framework Specification, PKT-SP-MIBS-I09-040730, CableLabs, July 30, 2004.
- [CH1.1] CableHome 1.1 Specification, CH-SP-I04-040409, April 9, 2004.⁷
- [OC] OpenCable Host Core Functional Requirements 2.0, OC-SP-HOST2.0-CFR-D01-040630, June 30, 2004.⁸

2.3 Reference Acquisition

CableLabs Specifications:

- Cable Television Laboratories, Inc., 858 Coal Creek Circle, Louisville, CO 80027; Phone 303-661-9100; Fax 303-661-9199; Internet: <http://www.cablelabs.com/>
- SCTE Standards, Society of Cable Telecommunication Engineers, 140 Philips Road, Exton PA 19341-1318, Phone 610-524-1725, www.scte.org
- IETF Standards, Internet Engineering Task Force (IETF) Secretariat c/o Corporation for National Research Initiatives, 1895 Preston White Drive, Suite 100, Reston, VA 20191-5434, Phone 703-620-8990, Fax 703-620-9071, Internet: www.ietf.org

⁴ Added per eDOCSIS-N-04.0151-3 by kb 7/18/04.

⁵ Added per eDOCSIS-N-04.0154-2 by kb 7/18/04.

⁶ Added per eDOCSIS-N-04.0154-2 by kb 7/18/04.

⁷ Edited per EDOCS-N-03084/ 11/11/03, po

⁸ Added per eDOCSIS-N-04.0151-3 by kb 7/18/04.

3 GLOSSARY

CMCI	Cable Modem (CM) to Customer Premise Equipment (CPE) Interface as defined in [DOCSIS-CMCI]
eCM	An eCM is an embedded Cable Modem, i.e., one that has been enhanced with the features of this specification.
eDOCSIS	eDOCSIS is the embedded DOCSIS specification that defines the interface between the eCM and an eSAFE.
eDOCSIS Device	An eDOCSIS Device is one that includes an eCM entity, one or more eSAFEs and supports a single software image using a DOCSIS secured software download mechanism. ⁹
Embedded Security eSTB	An eSTB with integrated security functions.
eMTA	Embedded Multimedia Terminal Adaptor. An embedded version of an MTA.
E-MTA	Embedded MTA device. An eDOCSIS device that contains both an eMTA and an eCM.
ePS	Embedded Portal Service Element. A CableHome-compliant eSAFE that provides management and network address translation functions between the DOCSIS network and the home network.
eSTB	Embedded Set-Top Box: An eSAFE that is compliant with [DSG], providing video, audio and data services. An example OpenCable-compliant eSTB is further specified in [OC]. ¹⁰
LCI	Logical CPE Interface. A bi-directional or uni-directional data-only logical 802.3/Ethernet MAC frame interface between eCM and an eSAFE. ¹¹
MTA	Multimedia Terminal Adapter as defined in [PC10-MTA]. Contains the interface to a physical voice device, a network interface, CODECs, and all signaling and encapsulation functions required for VoIP transport, class features signaling and QoS signaling.
eSAFE (embedded Service/Application Functional Entity)	An embedded version of CableLabs-specified application, such as a PacketCable Multimedia Terminal Adapter (MTA), that provides a service using the DOCSIS IP platform, or a function or set of functions, such as the CableHome Portal Services logical element, that supports the delivery of one or more services over an IP platform.
OpenCable Host eSTB	An eSTB device built to OpenCable Host specifications

⁹ Edited per EDOCS-N-03099, 11/11/03, po

¹⁰ Added per eDOCSIS-N-04.0151-3 by kb 7/18/04.

¹¹ Revised per eDOCSIS-N-04.0160-1 by kb 7/28/04.

4 ABBREVIATIONS

This specification uses the following abbreviations:¹²

CM	Cable Modem
CMCI	Cable Modem to Customer Premises Equipment Interface
DOCSIS	Data-Over-Cable Service Interface Specifications
DSG	DOCSIS Set-top Gateway
eCM	Embedded Cable Modem
eDOCSIS	Embedded DOCSIS
eMTA	Embedded MTA
ePS	Embedded Portal Services Element
eSTB	Embedded Set-Top Box
eSAFE	Embedded Service/Application Functional Entity
LCI	Logical CPE Interface
SLED	Software Loopback for eDOCSIS

¹² Table revised per ECNs eDOCSIS-N-04.0151-3, eDOCSIS-N-04.0160-1

5 EMBEDDED DOCSIS CABLE MODEM

5.1 Device Interface Reference Model

Referring to Figure 5-1, an eDOCSIS device consists of an embedded DOCSIS cable modem (eCM) and one or more embedded Service/Application Functional Entities (eSAFEs). An eDOCSIS device may also have one or more physically exposed interfaces. In addition, only a single secured software image download is used for the entire eDOCSIS device.

eSAFEs include:

- ePS: embedded CableHome Portal Services Logical Element [CH1.0]
- eMTA: embedded PacketCable Multimedia Terminal Adapter [PC10-MTA], [PC10-MIB]
- eSTB: Embedded Set-Top Box: An eSAFE that is compliant with [DSG], providing video, audio and data services. An example OpenCable-compliant eSTB is further specified in [OC].¹³

Within an eDOCSIS device, each eSAFE interfaces to the eCM via a point-to-point logical CPE interface.

Figure 5-2 presents a typical CableHome Home Access eDOCSIS Device reference model.

Figure 5-3 presents a logical view of protocol stacks for an eCM to ePS interface.

Figure 5-4 presents a typical PacketCable E-MTA (with DOCSIS cable modem) eDOCSIS Device reference model.

Figure 5-5 presents a logical view of protocol stacks for an eCM to eMTA interface.

Figure 5-6 presents a typical OpenCable Host 2.0 eDOCSIS Device reference model.¹⁴

Figure 5-7 presents a logical view of protocol stacks for an eCM to eSTB interface (OpenCable Host 2.0).¹⁵

Figure 5-8 presents a typical embedded security STB eDOCSIS Device reference model.¹⁶

Figure 5-9 presents a logical view of protocol stacks for an eCM to eSTB interface (embedded security STB).¹⁷

¹³ Added per eDOCSIS-N-04.0151-3 by kb 7/18/04.

¹⁴ Figure added per eDOCSIS-N-04.0151-3 by kb 7/18/04.

¹⁵ Figure added per eDOCSIS-N-04.0151-3 by kb 7/18/04.

¹⁶ Figure added per eDOCSIS-N-04.0151-3 by kb 7/18/04.

¹⁷ Figure added per eDOCSIS-N-04.0151-3 by kb 7/18/04.

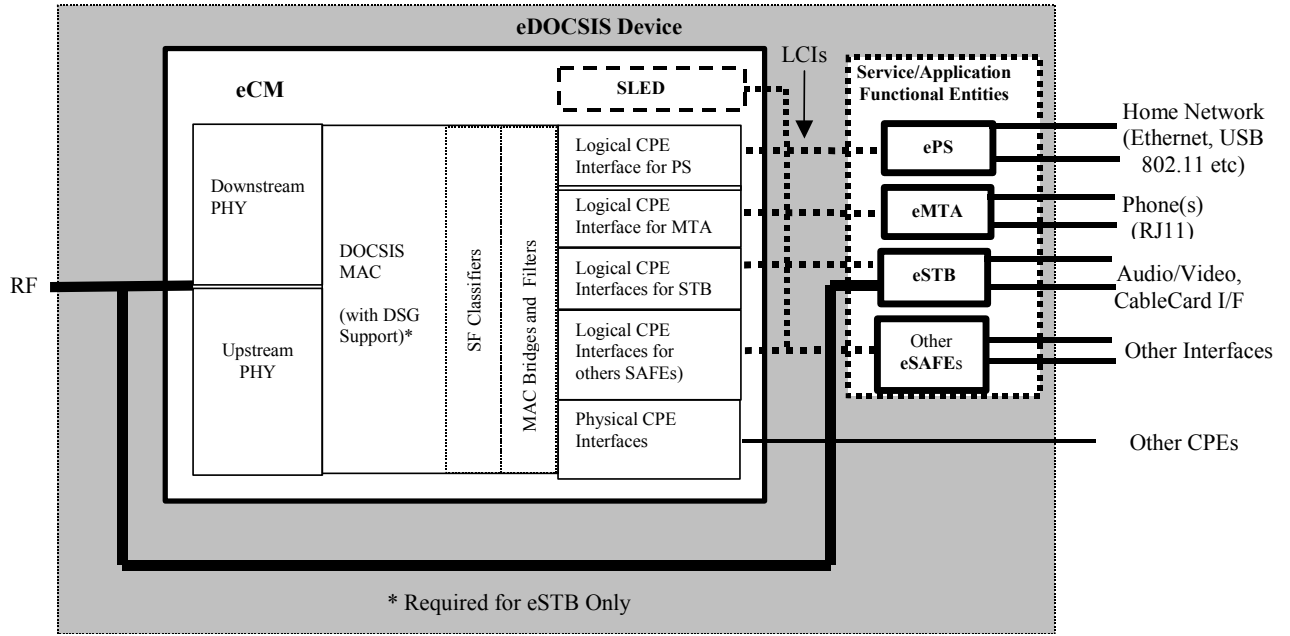

Figure 5-1 - eDOCSIS Reference Model

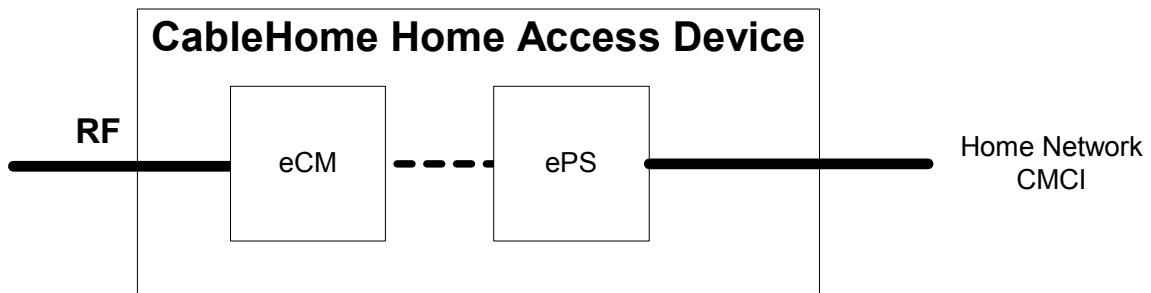

Figure 5-2 - CableHome Home Access eDOCSIS Device Reference Model

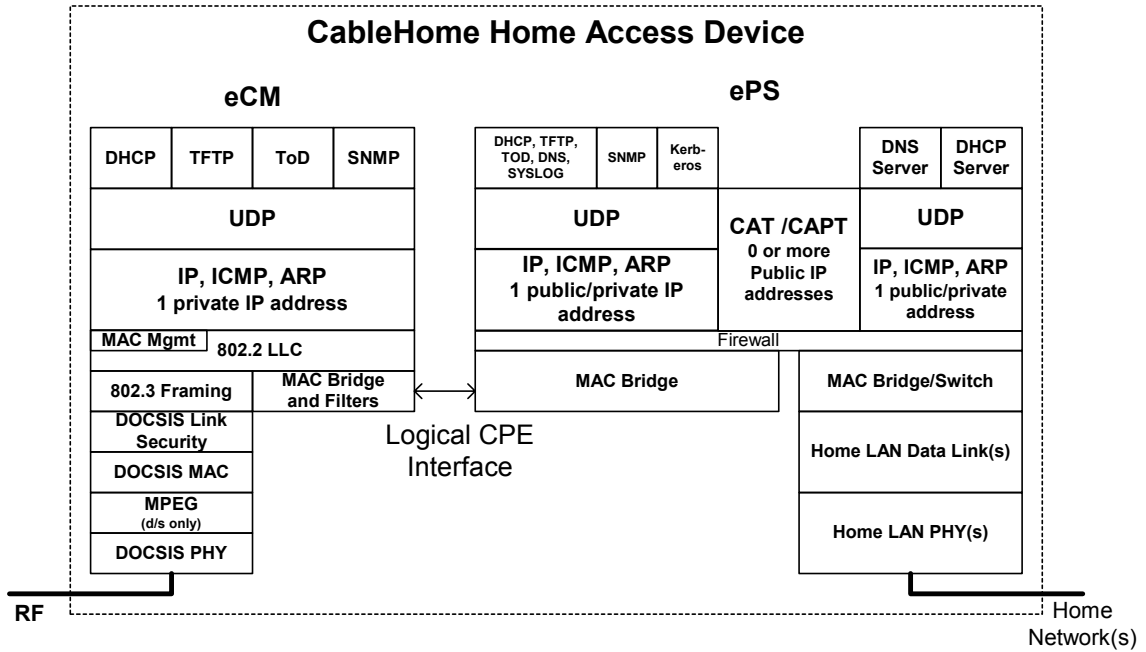

Figure 5-3 - eCM - ePS Protocol Stacks

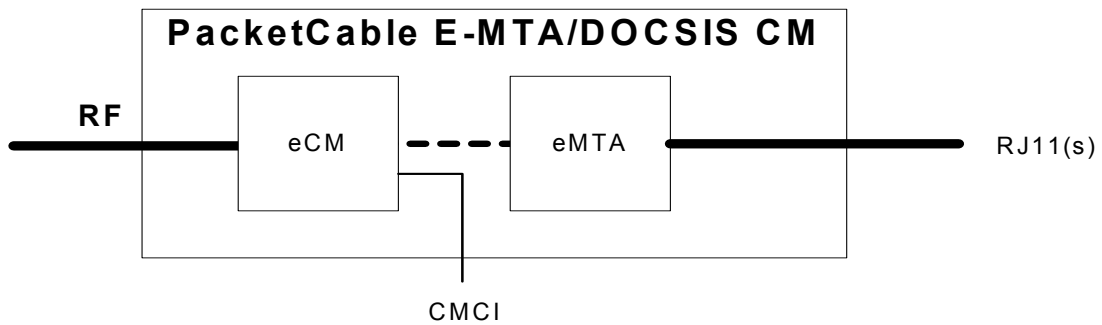

Figure 5-4 - PacketCable E-MTA (with DOCSIS CM) eDOCSIS Reference Model

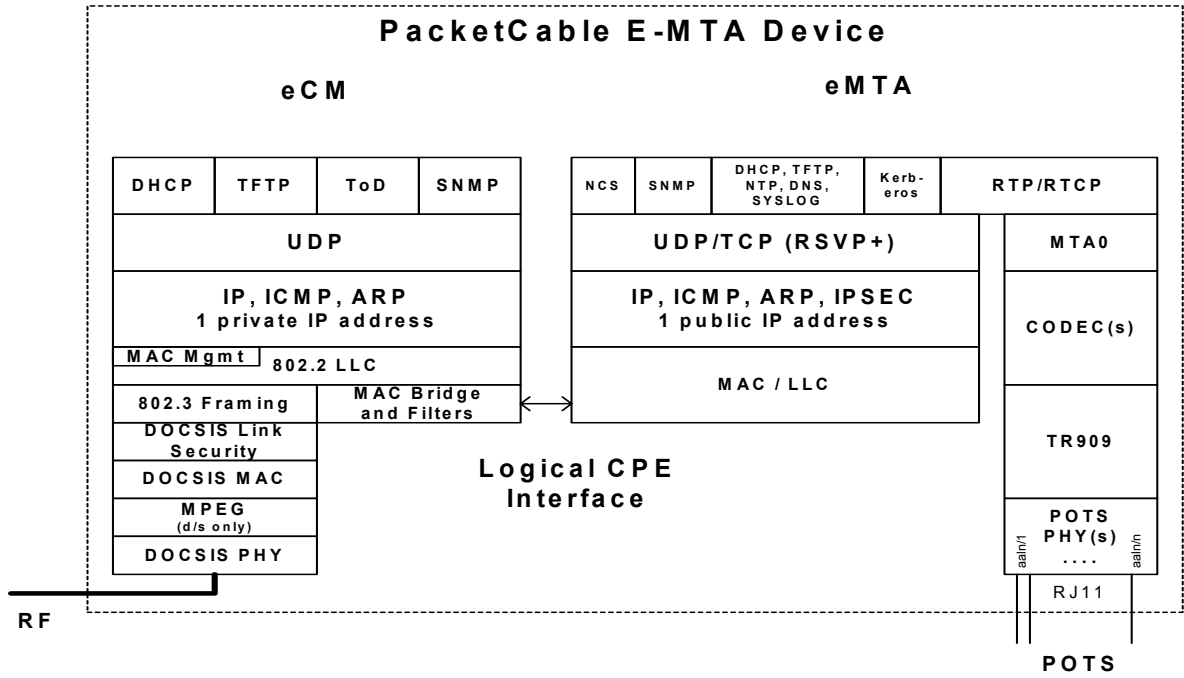

Figure 5-5 - eCM - eMTA Protocol Stacks

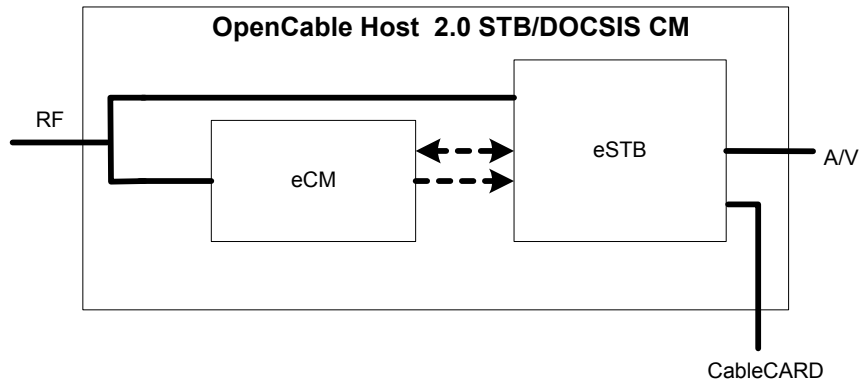

Figure 5-6 - OpenCable Host 2.0 eDOCSIS Reference Model

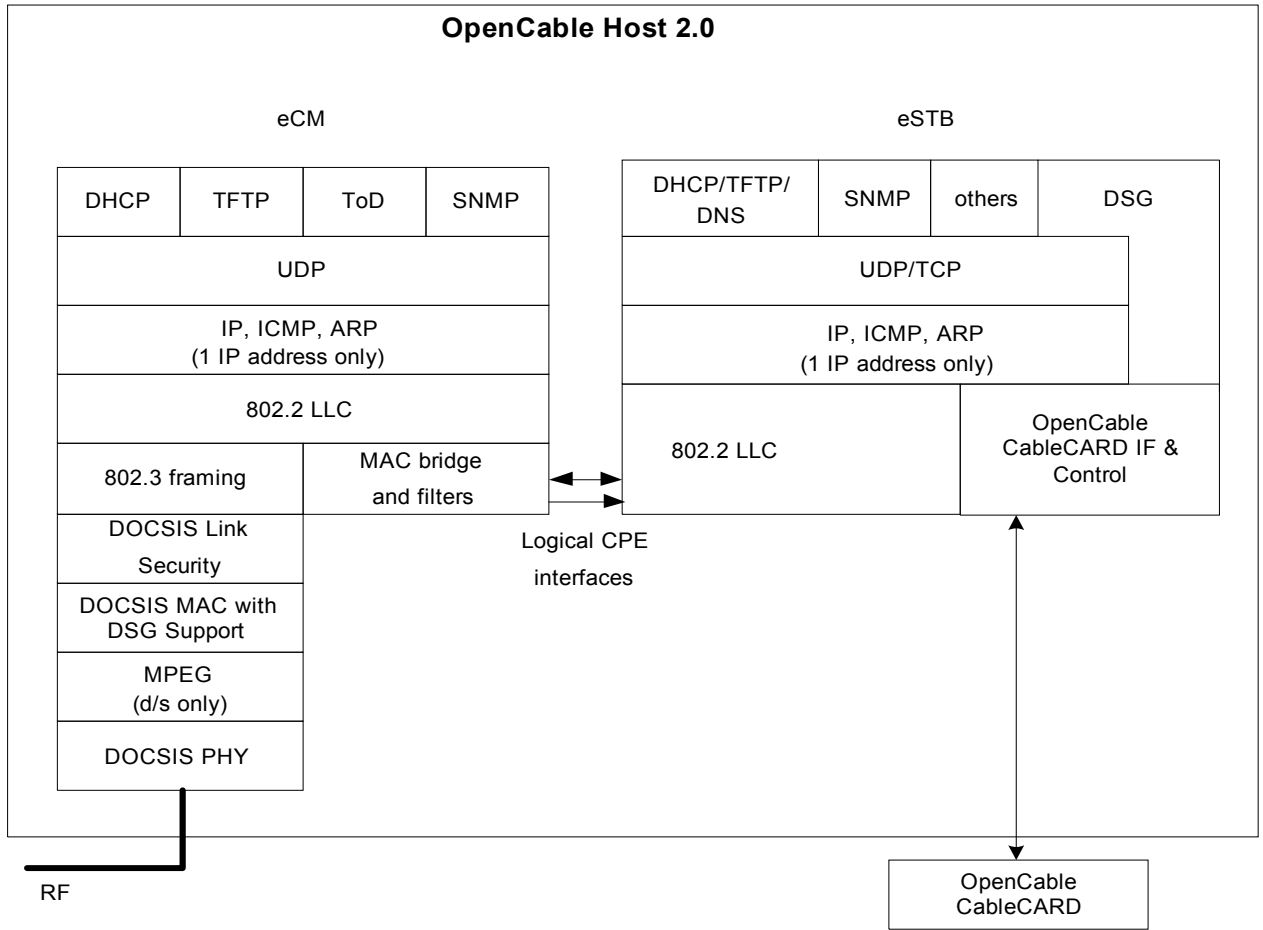

Figure 5-7 - eCM – eSTB Protocol Stacks – OpenCable Host 2.0

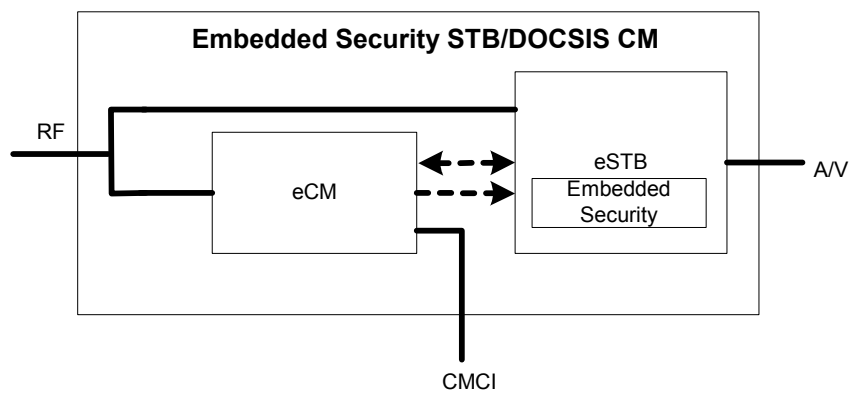

Figure 5-8 - Embedded Security STB eDOCSIS Reference Model

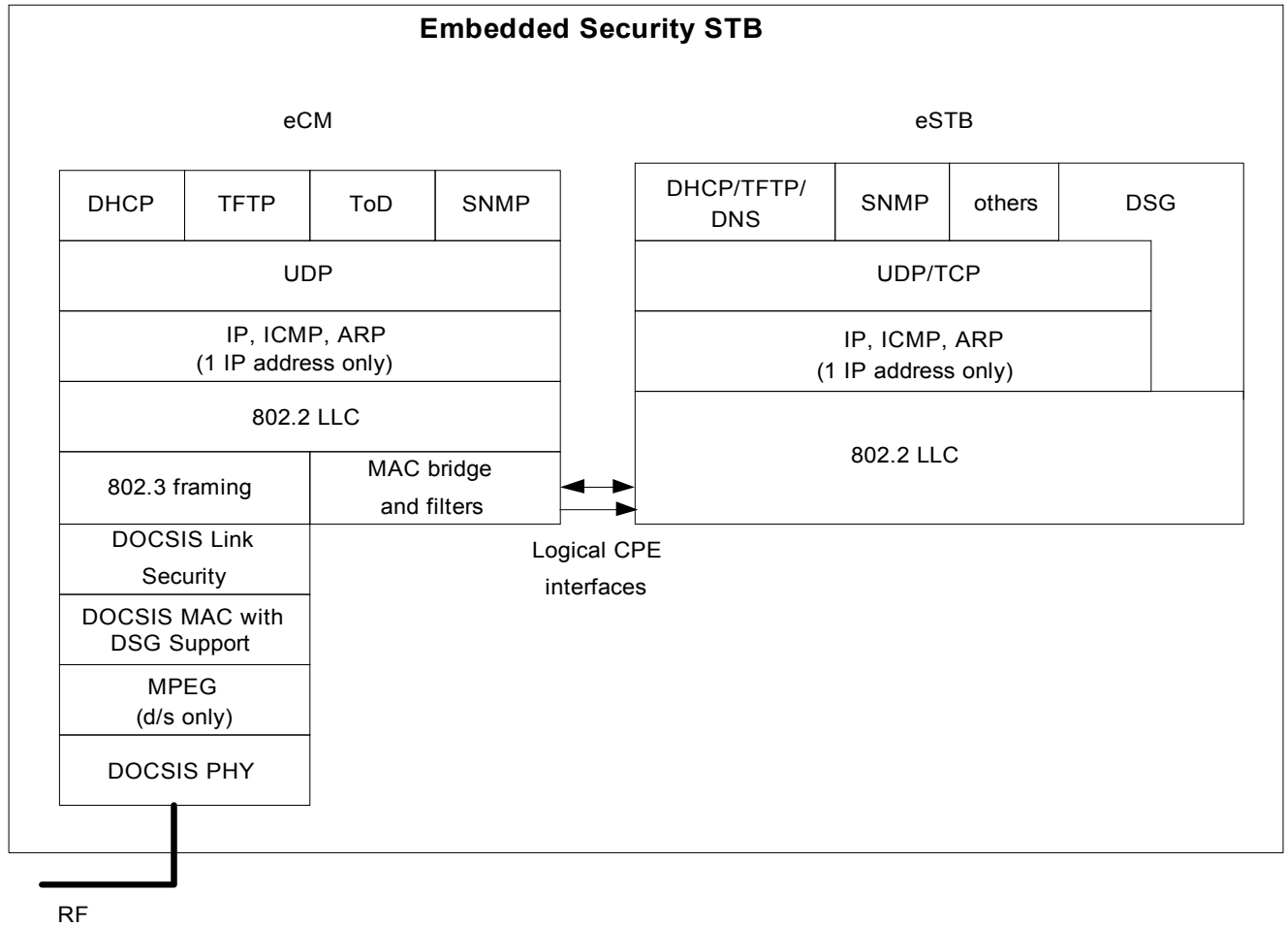

Figure 5-9 - eCM – eSTB Protocol Stacks – Embedded Security STB

5.2 eDOCSIS Requirements

5.2.1 General Requirements

The eCM will provide an SNMP agent which is logically separated from any SNMP agent provided by an eSAFE.

Except for MIB objects that are explicitly allowed to be shared, the DOCSIS-specified MIBs MUST only be accessible through the Management IP address of the eCM. The eSAFE-specified MIBs MUST NOT be accessible through the Management IP address of the eCM.

The MIB objects that MAY be shared are:

- the snmpGroup, systemGroup, udpGroup, icmpGroup and ipGroup (with the exception of ipNetToMediaTable and ipAddrTable within the ipGroup which MUST NOT be shared).
- the mibs rooted under snmpV2 (1.3.6.1.6).

The eCM MUST act as an entity distinct from, and MUST have logical CPE interfaces to, the eSAFEs.

All messages coming from the DOCSIS data network (labeled RF in the diagrams) destined for eSAFEs MUST be processed through the eCM first.

The eCM MUST be the only interface to the DOCSIS data network.

In addition, only a single secured software image download MUST be used for the entire eDOCSIS device and it MUST be controlled by the eCM.

For an eDOCSIS device containing an eSTB, the eCM MUST implement DSG client support functionality including one-way DOCSIS and DCD MAC message as specified in [DSG].¹⁸

An eCM, MUST meet the requirements of an equivalent standalone cable modem as specified in the applicable DOCSIS Base Specifications. In case any requirement in this document conflicts with a requirement in the DOCSIS Base Specifications (i.e. DOCSIS 1.0, 1.1 and DOCSIS 2.0), the requirement in this document takes precedence for any eDOCSIS Device.¹⁹

5.2.2 Interface Requirements

The bridging function between RF port and the CPE interfaces (logical or physical) MUST be equivalent to that of a multi-port learning bridge. Each CPE interface MUST comply with the CM Forwarding Rules defined in [DOCSISx-RFI]²⁰. In particular:²¹

- MAC addresses of each eSAFE MUST be counted toward the total allowed by the Maximum Number of CPEs configuration setting.
- Packet forwarding and filtering rules defined in [DOCSISx-RFI] specification MUST apply to both logical and physical interfaces to eSAFEs as defined in this specification and in [DOCSISx-OSSI]²².
- Data forwarding through the interfaces to all eSAFEs - with the exception of the interface to the DSG Client (ifIndex 18) - MUST obey the Network Access Control Object as defined in [DOCSISx-RFI]. NACO state does not affect the forwarding of DSG traffic (through ifIndex 18) in an eDOCSIS device containing an eSTB.

5.2.3 Operations Support Requirements

5.2.3.1 ifTable Requirements

The eCM MUST represent the logical interface to each eSAFE with an entry in the ifTable with ifType other(1) as described in [DOCSISx-OSSI] and as detailed below.

If the eCM is embedded into a device which contains an ePS, then:

- The eCM MUST use ifIndex 1 (the Primary CPE interface) to represent the logical interface between the eCM and the ePS.
- The eCM MUST NOT report in the ifTable the physically exposed interfaces associated with the ePS, and MUST NOT report the MIB Module extensions associated with those interfaces (e.g. EtherLike-MIB and USB-MIB).

If the eCM is embedded into a device which contains an eMTA, then:

- The eCM MUST use ifIndex 16 to represent the logical interface between the eCM and the

¹⁸ Paragraph added per eDOCSIS-N-04.0151-3 by kb 7/18/04.

¹⁹ Edited per EDOCS-N-03099, 11/11/03, po

²⁰[DOCSISx-RFI] is a shorthand notation for [RFI 1.0], [RFI 1.1], and [RFI 2.0]

²¹ Section modified per eDOCSIS-N-04.0150-2, 7/12/04, kb

²²[DOCSISx-OSSI] is a shorthand notation for [OSSI 1.0], [OSSI 1.1], and [OSSI 2.0]

eMTA.

- The eCM MUST NOT report in the ifTable the MTA endpoints (ifType = 198).

If the CM is embedded into a device which contains an eSTB, then:²³

- The eCM MUST use ifIndex 17 to represent the logical interface between the eCM and the eSTB for the interactive IP traffic.
- The eCM MUST use ifIndex 18 to represent the logical interface between the eCM and the eSTB for the one-way DSG tunnel traffic.
- The eCM MUST NOT report in the ifTable any other interfaces on the eSTB (such as CableCARD, DSG Clients, and A/V interfaces, etc) which are not directly and physically connected to the eCM.

The ifXTable MUST be supported in accordance with [RFC 2863]. The Default value of ifLinkUpDownTrapEnable MUST be enabled(1) for logical interfaces to eSAFEs.

The ifStackTable MUST be supported in accordance with [RFC 2863]. The logical interface to an eSAFE MUST NOT contain any sub-layers.

Table 5-1 summarizes the ifIndex assignments in the eCM. Table 5-2 defines the details of the ifTable entries that MUST be supported by ePS, eMTA and eSTB.²⁴

Table 5-1 - eDOCSIS ifTable Interface Designations

Interface	Type
1	Primary CPE interface (CableHome ePS WAN interface)
2	CATV-MAC
3	RF-downstream channel
4	RF-Upstream channel
5 – 15	Other CPE Interfaces
16	Reserved for PacketCable/eMTA
17	Reserved for eSTB-IP ²⁵
18	Reserved for eSTB-DSG ²⁶
19 – 31	Reserved for Other eDOCSIS Interfaces

An eDOCSIS compliant eCM can have multiple CPE interfaces, as well as interfaces to multiple eSAFEs. If filter(s) (IP, LLC, or NmAccess) are applied to the eCM’s “Primary CPE Interface” (ifIndex 1), the eCM MUST also apply the same filter(s) to its “Other CPE Interfaces” (ifIndexes 5 through 15). Moreover, filters are never used to limit traffic between the CPE interfaces (“Primary CPE Interface” and “Other CPE Interfaces”) within the eCM. However, if IP, LLC, or NmAccess filters are applied to the eCM’s “Primary

²³ Paragraph and bullets added per eDOCSIS-N-04.0151-3 by kb 7/18/04.

²⁴ Sentence modified per eDOCSIS-N-04.0151-3 by kb 7/18/04.

²⁵ Row added per eDOCSIS-N-04.0151-3 by kb 7/18/04.

²⁶ Row added per eDOCSIS-N-04.0151-3 by kb 7/18/04.

CPE Interface” (ifIndex 1), the eCM MUST NOT apply these filters to ifIndex 16 through 31, which are reserved as interfaces to eSAFEs. ²⁷

The above defined mechanism provides granular, independent control of filters applied to the CPE Interfaces versus those applied to the interface to each eSAFE. In addition, the eCM MUST have the ability to filter traffic at a particular interface to an eSAFE, regardless of the origination point of that traffic. This granular filter control provides the ability for the eCM to filter traffic sourced by one eSAFE that is destined to another eSAFE within the same device.²⁸

Table 5-2 - [RFC 2863] ifTable, MIB-Object Details for eDOCSIS Device Interfaces

[RFC 2863] MIB-Object details for eCM-eSAFE Interfaces	ePS	eMTA	eSTB ²⁹	
			eSTB-IP	eSTB-DSG
ifIndex	1	16	17	18
ifDescr: MUST match the text	"CableHome Embedded Interface"	"PacketCable Embedded Interface" ³⁰	"Set-Top Box Embedded IP Interface"	"Set-Top Box Embedded DSG Interface"
ifType	other(1)	other(1)	other (1)	other (1)
ifMtu	0	0	0	0
ifSpeed	0	0	0	0
ifPhysAddress	<empty-string>	<empty-string> ³¹	<empty-string>	<empty-string>
ifAdminStatus: Only up/own control are required for this interface. Other values are optional	up(1), down(2)	up(1), down(2)	up(1), down(2)	up(1), down(2)
ifOperStatus: Only up/own control are required for this interface. Other values are optional	up(1), down(2)	up(1), down(2)	up(1), down(2)	up(1), down(2)
ifLastChange	<per [RFC 2863]>	<per [RFC 2863]> ³²	<per [RFC 2863]>	<per [RFC 2863]>
ifInOctets	(n)	(n)	(n)	Deprecated
ifInUCastPkts	(n)	(n)	(n)	Deprecated
ifInNUCastPkts	Deprecated	Deprecated	Deprecated	Deprecated
ifInDiscards	0	0	0	0
ifInErrors	0	0	0	0
ifUnknownProtos	0	0	0	0
ifOutOctets	(n)	(n)	(n)	(n)

²⁷ Paragraph added by eDOCSIS-N-04.0153-2 by kb

²⁸ Paragraph added by eDOCSIS-N-04.0153-2 by kb

²⁹ Columns added per eDOCSIS-N-04.0151-3 by kb 7/18/04.

³⁰ Edited per EDOCS-N-03099, 11/11/03, po

³¹ Edited per EDOCS-N-03099, 11/11/03, po

³² Edited per EDOCS-N-03099, 11/11/03, po

[RFC 2863] MIB-Object details for eCM-eSAFE Interfaces	ePS	eMTA	eSTB ²⁹	
			eSTB-IP	eSTB-DSG
ifOutUCastPkts	(n)	(n)	(n)	(n)
ifOutNUCastPkts	Deprecated	Deprecated	Deprecated	Deprecated
ifOutDiscards	0	0	0	0
ifOUtErrors	0	0	0	0
ifOutQlen	Deprecated	Deprecated	Deprecated	Deprecated
ifSpecific	Deprecated	Deprecated	Deprecated	Deprecated

5.2.3.2 [RFC 2011] ipNetToMediaTable Requirements

Table 5-3 shows the details of the ipNetToMediaTable entries that MUST be supported by ePS, eMTA, and eSTB.

Table 5-3 - [RFC 2011] ipNetToMedia MIB-Object Details for eDOCSIS Device Interfaces

[RFC 2011] MIB-Object details for eCM-eSAFE Interfaces	ePS	eMTA	eSTB-IP ³³
ipNetToMediaIfIndex	1	16	17
ipNetToMediaPhysAddress	WAN-Man MAC Address	MTA MAC Address	STB MAC Address
ipNetToMediaNetAddress	WAN-Man Address, if acquired; otherwise 0.0.0.0	MTA Address, if acquired; otherwise 0.0.0.0	STB IP Address, if acquired; otherwise 0.0.0.0
ipNetToMediaType	static(4)	static(4)	static(4)

5.2.3.3 [RFC 1493] Requirements³⁴

The eCM MUST add ports associated with eSAFEs to its [RFC 1493] dot1dBasePortTable.

The eCM MUST support all bridge statistics of the [RFC 1493] dot1dTpPortTable for all ports associated with eSAFEs.

The eCM MUST create a row entry in its dot1dTpFdbTable for each active eSAFE MAC address within the eDOCSIS device.

Within each dot1dTpFdbTable entry for an eSAFE, the dot1dTpFdbAddress value MUST be the eSAFE MAC address, the dot1dTpFdbPort value MUST be the port associated with the ifIndex of that eSAFE from the dot1dBasePortTable, and the dot1dTpFdbStatus value MUST be mgmt(5). The eCM MUST prevent row entries for eSAFEs from being aged-out or overwritten.

An eDOCSIS device containing an eSTB MUST implement the objects from the [RFC 1493] dot1dStaticTable with a MAX-ACCESS of read-only.

³³ Column added per eDOCSIS-N-04.0151-3 by kb 7/18/04.

³⁴ Section replaced per eDOCSIS-N-04.0158-2 by kb 7/18/04.

In an eDOCSIS device containing an eSTB, the eCM will acquire the DSG MAC addresses from the eSTB in an implementation-dependant manner. For each DSG MAC address acquired by the eCM, the eCM MUST create a corresponding row entry in the dot1dStaticTable.

For a dot1dStaticTable row entry for a DSG MAC address, the dot1dStaticAddress value MUST be the DSG MAC address, the dot1dStaticReceivePort value MUST be the port associated with ifIndex 2 (CATV-MAC interface) from the dot1dBasePortTable, the dot1dStaticAllowedToGoTo value MUST be the port associated with the ifIndex 18 (interface to the DSG Client of the eSTB) from the dot1dBasePortTable, and the dot1dStaticStatus value MUST be deleteOnReset(4).

Table 5-4 - dot1dStaticTable Entries for DSG MAC Addresses

MIB Object	Value
dot1dStaticAddress	DSG MAC Address
dot1dStaticReceivePort	port associated with ifIndex 2 in dot1dBasePortTable
dot1dStaticAllowedToGoTo	port associated with ifIndex 18 in dot1dBasePortTable
dot1dStaticStatus	deleteOnReset(4)

Each row entry in the dot1dStaticTable describes a bridging rule in which the eCM only bridges a frame with a destination address of the value of dot1dStaticAddress—that is received from the port represented by the value of dot1dStaticReceivePort—if the frame is to be bridged out a port included in the value of dot1dStaticAllowedToGoTo.

An eCM MUST NOT bridge a frame having a destination address equal to an active DSG MAC address if that frame was received from any port other than the one associated with ifIndex 2 (CATV-MAC).

An eCM MUST NOT bridge a frame having a destination address equal to an active DSG MAC address to any port other than the one associated with ifIndex 18 (the interface to the DSG Client of the eSTB).

5.2.4 DHCP Option 43 Syntax Requirements

In order to facilitate device provisioning, all eDOCSIS devices will use DHCP Option 43 during registration process for providing vendor class identification, embedded component and vendor specific capability enumerations.

5.2.4.1 General Requirements

Each eCM DHCP DISCOVER and DHCP REQUEST MUST use Option 43 and its Sub-options 2 through 10 for Vendor Specific Information to identify embedded components as specified in Table 5-5.

Similarly, each eSAFE may issue its own DHCP DISCOVER and DHCP REQUEST with Option 43 after eCM has been successfully registered and operational; details are specified in each eSAFE's specification.

5.2.4.2 DHCP Option 43 Syntax

DHCP Option 43 provides device specific information through the use of sub-options. Sub-options 1 through 10 are specified by CableLabs, sub-options 11-127 are reserved for future CableLabs use, and sub-options 128 and above are reserved for vendor use.

The eCM MUST implement the Vendor Specific Information Option (DHCP option 43) as specified in Table 5-5. Details of DHCP option 43 and its sub-options for eDOCSIS are further defined below. The definitions of DHCP Option 43 sub-options MUST conform to requirements imposed by [RFC 2132].

The option begins with a type octet with the value of number 43, followed by a length octet. The length octet is followed by the number of octets of data equal to the value of the length octet. The value of the length octet does not include the two octets specifying the tag and length.

DHCP option 43 in eDOCSIS is a compound option. The content of option 43 is composed of one or more sub-options. Supported DHCP option 43 sub-options in eDOCSIS is in the range 1-254. A sub-option begins with a tag octet containing the sub-option code, followed a length octet which indicates the total number of octets of data. The value of the length octet does not include itself or the tag octet. The length octet is followed by "length" octets of sub-option data.

5.2.4.3 DHCP Option 43 Sub-option Encoding

The encoding of each Option 43 sub-option is defined below. See Table 5-5 for the intended purpose of each sub-option.

The eCM MAY include Option 43 sub-option 1 in DHCPDISCOVER and DHCPREQUEST messages. If DHCP Option 43 sub-option 1 is included in these DHCP client messages, the eCM MUST encode this sub-option by the number of octets equal to the value of the length octet of this sub-option, with each octet codifying a requested sub-option. If the length octet of this sub-option is 0 (because there are no requested sub-options), this sub-option SHOULD be omitted from DHCP Option 43.³⁵

The eCM MUST encode each of the DHCP Option 43 sub-options 2, 3, 4, 5, 6, 7, 8, 9 and 10 as a character string consisting of characters from the NVT ASCII character set, with no terminating NULL.

An eCM MUST send DHCP Option 43 sub-option 2 containing the character string "ECM" (without the quotation marks).

An eCM MUST send DHCP Option 43 sub-option 3 containing a colon-separated list of all eSAFE types in the eDOCSIS device, including at a minimum the colon-separated character string "ECM:<eSAFE>" (without the quotation marks).

Defined eSAFEs are: "EPS" for CableHome embedded Portal Services Element, "EMTA" for PacketCable embedded MTA, and "ESTB" for embedded set-top box.³⁶

An eCM MUST send DHCP Option 43 sub-option 4 containing the device serial number as in MIB object docsDevSerialNumber.

An eCM MUST send DHCP Option 43 sub-option 5 containing the Hardware version number, identical to the value as reported in <Hardware version> field in MIB object sysDescr.

An eCM MUST send DHCP Option 43 sub-option 6 containing the Software version number, identical to the value as reported in <Software version> field in MIB object sysDescr.

An eCM MUST send DHCP Option 43 sub-option 7 containing the Boot ROM version number, identical to the value as reported in <Boot ROM version> field in MIB object sysDescr.

An eCM MUST send DHCP Option 43 sub-option 8 containing a 6³⁷-octet, hexidecimally-encoded, vendor-specific Organization Unique Identifier (OUI) that uniquely identifies the eCM manufacturer. A

³⁵ Paragraph modified per eDOCSIS-N-04.0123-2 and eDOCSIS-N-04.0134-2 by kb 7/18/04.

³⁶ Paragraph modified per eDOCSIS-N-04.0151-3 by kb 7/18/04.

vendor MAY use the same OUI as in the eCM's MAC address, and MAY use a single OUI to identify all its eDOCSIS products.

An eCM MUST send DHCP Option 43 sub-option 9 containing the Model number, identical to the value as reported in <Model number> field in MIB object sysDescr.

An eCM MUST send DHCP Option 43 sub-option 10 containing the Vendor name, identical to the value as reported in <Vendor name> field in MIB object sysDescr.

In eDOCSIS, DHCP Option 43 sub-option 11-127 are reserved for eSAFEs and CableLabs, and MUST NOT be used for other purpose. The partitions are as follows:

- Sub-options 11 to 30: reserved for CableHome use,
- Sub-options 31 to 50 : reserved for PacketCable use,
- Sub-options 51 to 127: reserved for future Cablelabs use.

In eDOCSIS, DHCP Option 43 sub-option 128-254 are reserved for vendors and MAY be used by vendors.

If the total number of octets in all DHCP Option 43 sub-options exceeds 255 octets, the eCM MUST follow [RFC 3396] to split the option into multiple smaller options.

Table 5-5 - DHCP Option 43 Syntax

eCM DHCP Option 43	Value	Description
Sub-option 1		The request sub-option vector is a list of sub-options (within option 43) to be returned to client by the server upon reply to the request. None defined.
Sub-option 2	"ECM"	Device type of the component making the DHCP request. For DOCSIS, this is: <ul style="list-style-type: none"> • "ECM"= embedded Cable Modem (as specified by DOCSIS 1.0, 1.1, or 2.0 Base Specifications)
Sub-option 3 ³⁸	"ECM: <eSAFE ₁ :eSAFE ₂ ... SAFE _n >"	Colon-separated list of eCM and eSAFE(s) contained in the complete eDOCSIS device. First on the list MUST be "ECM" for eCM. <eSAFE _x > can be "EMTA", "EPS", or "ESTB" corresponding to embedded MTA, embedded Portal Service Element, and embedded STB, respectively. For example: <ul style="list-style-type: none"> • "ECM:EMTA" = A PacketCable/Embedded MTA • "ECM:EPS" = A CableHome/Embedded Portal Services Element • "ECM:ESTB" = An Embedded STB • "ECM:EMTA:EPS" = An Embedded MTA and Embedded Portal Services Element
Sub-option 4	"<device serial number>"	Device serial number as in MIB object docsDevSerialNumber e.g. "123456"
Sub-option 5	"<Hardware version>"	Hardware version number. Identical to value as reported in the <Hardware version> field in MIB object sysDescr. e.g. "v.3.2.1"
Sub-option 6	"<Software version>"	Software version number. Identical to value as reported in the <Software version> field in MIB object sysDescr. e.g. "v.1.0.2"

³⁷ Changed from 3 to 6 by eDOCSIS-N-04.0123-2 by kb 7/30/04.

³⁸ Modified per eDOCSIS-N-04.0151-3 by kb 7/18/04.

eCM DHCP Option 43	Value	Description
Sub-option 7	"<Boot ROM version>"	Boot ROM version. Identical to value as reported in the <Boot ROM version> field in MIB object sysDescr. e.g. "Bv4.5.6"
Sub-option 8	"<OUI>"	A 6-octet, hexidecimally-encoded, vendor-specific Organization Unique Identifier (OUI) that may match the OUI in eCM's MAC address. ³⁹
Sub-option 9	"<Model number>"	Device model number. Identical to value as reported in the <Model number> field in MIB object sysDescr. e.g. "T3000"
Sub-option 10	"<Vendor name>"	Vendor name or ID. Identical to value as reported in the <Vendor name> field in MIB object sysDescr. e.g. "XYZ Corp"
Sub-options 11 to 127		Reserved for CableLabs.
Sub-options 128 to 254		Reserved for vendors.

5.2.4.4 Examples (Informative)

5.2.4.4.1 DOCSIS Cable Modem with Embedded PacketCable 1.0 MTA Example

Table 5-6 shows the syntax for DHCP Option 43 for the eCM in an E-MTA.

Table 5-6 - Example eDOCSIS Device: E-MTA

DHCP DISCOVER Options	Value	Description
eCM DHCP DISCOVER		
eCM Option 43 sub-option 1	N/A (omitted because the list is empty) ⁴⁰	List of sub-options (within option 43) to be returned by server
eCM Option 43 sub-option 2	"ECM"	Embedded cable modem
eCM Option 43 sub-option 3	"ECM:EMTA"	ECM followed by a list of embedded components (eSAFEs)
eCM Option 43 sub-option 4	"123456"	Device serial number as in MIB object docsDevSerialNumber
eCM Option 43 sub-option 5	"V1.2.3"	Hardware version number as in <Hardware version> field in MIB object sysDescr.
eCM Option 43 sub-option 6	"V3.2.1"	Software version number as in <Software version> field in MIB object sysDescr
eCM Option 43 sub-option 7	"Boot 4.5.6"	Boot ROM version number as in <Boot ROM version> field in MIB object sysDescr
eCM Option 43 sub-option 8	"0204DF"	6-octet OUI as Vendor ID ⁴¹

³⁹ Modified per eDOCSIS-N-04.0123-2 by kb 7/18/04.

⁴⁰ Modified per eDOCSIS-N-04.0123-2 by kb 7/18/04.

⁴¹ Modified per eDOCSIS-N-04.0123-2 by kb 7/18/04.

DHCP DISCOVER Options	Value	Description
eCM DHCP DISCOVER		
eCM Option 43 sub-option 9	“Xman200”	Device model number as in <Model number> field in MIB object sysDescr
eCM Option 43 sub-option 10	“XYZ Broadband”	Vendor name as in <Vendor name> field in MIB object sysDescr

5.2.4.4.2 DOCSIS Cable Modem with Embedded CableHome 1.1 PS Example

Table 5-7 shows the syntax for DHCP Options 43 for the eCM in a CableHome 1.1 E-PS device.

Table 5-7 - Example eDOCSIS Device: DOCSIS 1.1 CableHome/E-PS

DHCP DISCOVER Options	Value	Description
eCM DHCP DISCOVER		
eCM Option 43 sub-option 1	N/A (omitted because the list is empty) ⁴²	List of sub-options (within option 43) to be returned by server
eCM Option 43 sub-option 2	"ECM"	Embedded cable modem
eCM Option 43 sub-option 3	"ECM:EPS"	ECM followed by a list of embedded components (eSAFEs)
eCM Option 43 sub-option 4	"123456"	Device serial number as in MIB object docsDevSerialNumber
eCM Option 43 sub-option 5	"V1.2.3"	Hardware version number as in <Hardware version> field in MIB object sysDescr.
eCM Option 43 sub-option 6	"V3.2.1"	Software version number as in <Software version> field in MIB object sysDescr
eCM Option 43 sub-option 7	“Boot 4.5.6”	Boot ROM version number as in <Boot ROM version> field in MIB object sysDescr
eCM Option 43 sub-option 8	“0204DF”	6-octet OUI as Vendor ID ⁴³
eCM Option 43 sub-option 9	“Xman200”	Device model number as in <Model number> field in MIB object sysDescr
eCM Option 43 sub-option 10	“XYZ Broadband”	Vendor name as in <Vendor name> field in MIB object sysDescr

⁴² Modified per eDOCSIS-N-04.0123-2 by kb 7/18/04.

⁴³ Modified per eDOCSIS-N-04.0123-2 by kb 7/18/04.

5.2.4.4.3 DOCSIS Cable Modem with Embedded STB Example⁴⁴

Table 5-8 illustrates the syntax for DHCP Options 43 for the eCM with an embedded STB.

Table 5-8 - Example eDOCSIS Device: DOCSIS 1.1 Embedded STB

DHCP DISCOVER & REQUEST Options	Options Value	Description
eCM DHCP DISCOVER & REQUEST		
eCM Option 43 sub-option 1	"<null>"	The request sub-option vector is a list of sub-options (within option 43) to be returned to client by the server upon reply to the request. None defined.
eCM Option 43 sub-option 2	"ECM"	Device type of the entity making the DHCP request. For DOCSIS, this is: <ul style="list-style-type: none"> "ECM" = embedded Cable Modem (as specified by DOCSIS 1.0, 1.1, or 2.0 Base Specifications)
eCM Option 43 sub-option 3	"ECM:ESTB"	Colon-separated list of eCM and eSAFE(s) contained in the device. First on the list MUST be "ECM". <ul style="list-style-type: none"> "ECM" = embedded CM "ESTB" = embedded STB
eCM Option 43 sub-option 4	e.g., "123456"	Device serial number from MIB object docsDevSerialNumber
eCM Option 43 sub-option 5	e.g., "V1.2.3"	Hardware version number from <Hardware version> field in MIB object sysDescr.
eCM Option 43 sub-option 6	e.g., "V3.2.1"	Software version number from <Software version> field in MIB object sysDescr
eCM Option 43 sub-option 7	"Boot 4.5.6"	Boot ROM version number from <Boot ROM version> field in MIB object sysDescr
eCM Option 43 sub-option 8	"0204DF"	A 6-octet, hexidecimally-encoded, vendor-specific Organization Unique Identifier (OUI) that may match the OUI in the eCM's MAC address.
eCM Option 43 sub-option 9	"Xman200"	Device model number from <Model number> field in MIB object sysDescr
eCM Option 43 sub-option 10	"XYZ Broadband"	Vendor name as in <Vendor name> field in MIB object sysDescr

5.2.4.4.4 DOCSIS Cable Modem with Embedded PacketCable MTA and CableHome PS

Table 5-9 shows the syntax for DHCP Option 43 for the eCM in an eDOCSIS device that contains the following embedded components: a DOCSIS 2.0 eCM, a PacketCable 1.0 eMTA and a CableHome 1.1 ePS.

⁴⁴ Section added per eDOCSIS-N-04.0151-3 by kb 7/18/04.

Table 5-9 - Example eDOCSIS Device Containing DOCSIS 2.0 eCM, eMTA and ePS

DHCP DISCOVER Options	Value	Description
eCM DHCP DISCOVER		
eCM Option 43 sub-option 1	N/A (omitted because the list is empty) ⁴⁵	List of sub-options (within option 43) to be returned by server
eCM Option 43 sub-option 2	"ECM"	Embedded cable modem
eCM Option 43 sub-option 3	"ECM:EMTA:EPS"	ECM followed by a list of embedded components (eSAFEs)
eCM Option 43 sub-option 4	"123456"	Device serial number as in MIB object docsDevSerialNumber
eCM Option 43 sub-option 5	"V1.2.3"	Hardware version number as in <Hardware version> field in MIB object sysDescr.
eCM Option 43 sub-option 6	"V3.2.1"	Software version number as in <Software version> field in MIB object sysDescr
eCM Option 43 sub-option 7	"Boot 4.5.6"	Boot ROM version number as in <Boot ROM version> field in MIB object sysDescr
eCM Option 43 sub-option 8	"0204DF"	6-octet OUI as Vendor ID ⁴⁶
eCM Option 43 sub-option 9	"Xman200"	Device model number as in <Model number> field in MIB object sysDescr
eCM Option 43 sub-option 10	"XYZ Broadband"	Vendor name as in <Vendor name> field in MIB object sysDescr ⁴⁷

5.2.5 Testability Requirements

In order to verify conformance to this specification and to the DOCSIS Base Specifications, a mechanism to generate and receive traffic bridged through the eCM is required. eDOCSIS devices that have a physically exposed CMCI (e.g., 10BaseT or USB) can be tested by using external packet generation equipment connected to that interface.

For cost, security, or other reasons, however, certain eDOCSIS devices may not have an exposed CMCI, necessitating an alternative mechanism.

Additionally, an eDOCSIS device may have multiple eSAFEs, each with a logical CPE interface (LCI) to the eCM. This specification places requirements on the LCIs as well as the bridging of traffic among eCM and eSAFEs.

To this end, a Software Loopback for eDOCSIS (SLED) is specified below.

5.2.5.1 General Requirements

An eCM SHOULD implement SLED. An eCM without an externally accessible CMCI port, or a physical interface configured to be equivalent to a CMCI port, MUST implement SLED.

⁴⁵ Modified per eDOCSIS-N-04.0123-2 by kb 7/18/04.

⁴⁶ Modified per eDOCSIS-N-04.0123-2 by kb 7/18/04.

⁴⁷ Edited per EDOCS-N-03084, 11/11/03, po

5.2.5.2 SLED Protocol Description

5.2.5.2.1 General Description

SLED is an embedded test function residing in an eCM enabling DOCSIS and eDOCSIS conformance testing coverage, particularly when an exposed CMCI is not available.

The SLED test functions are controlled via SLED MIB objects as specified in Annex A. The SLED MIB objects MUST be associated with the SNMP stack of the eCM. The SLED MIB objects MUST NOT be accessible through the CMCI.

To prevent unintended activation of SLED, all SLED functions MUST be disabled by default. SLED functions MUST only be enabled if the MIB object *sledGlobalEnable* is set to 'true' prior to eCM registration; *sledGlobalEnable* may be set to 'true' via inclusion in TLV-11 of the eCM's configuration file.

The SLED MIB values revert to power-on values when the CM de-registers or loses Operational state; the *sledGlobalEnable* will revert to 'false' and in-progress packet generation or loopback will be stopped.⁴⁸

Figure 5-10 illustrates the SLED reference model.

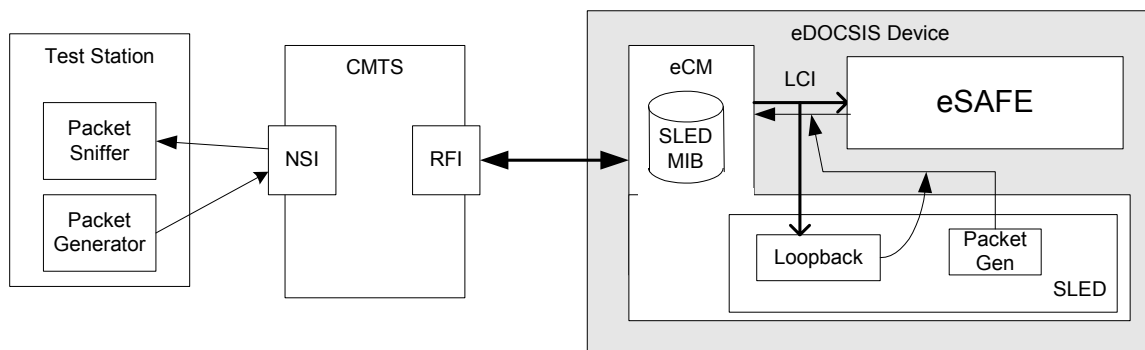

Figure 5-10 - SLED Reference Model

The SLED functionality supports:

1. Packet loopback

The primary purpose of the Packet loopback protocol is to enable verification of the receipt of packets across the LCI by the eSAFE. Once enabled by the SLED MIB object, all packets that are forwarded to the indicated LCI are encapsulated into a pre-defined packet header (Ethernet DIX frame header + IP header + UDP header) and reflected back across the LCI to the eCM for forwarding to the final destination. Typically, the looped-back packets will be addressed to, and captured by, a test station residing in the Network-Side Interface (NSI) of the CMTS.
2. Packet generation

SLED MIB objects are defined to enable setting up of Ethernet framing and payload transmission for packet generation and transmission through the LCI to the eCM. The SLED MIB objects described below control the packet transmission with parameters such as Ethernet packet header, packet rate, and the number of packets.

⁴⁸ Paragraph added per eDOCSIS-N-04.0122-2 by kb 7/18/04.

3. Packet loopback and packet generation SLED functions MUST be able to be controlled independently.
4. The packet loopback and packet generation SLED functions MUST NOT disrupt network connectivity to or from the eSAFE. When SLED loopback is enabled, a packet transmitted across the LCI in the eCM-to-eSAFE direction, MUST be forwarded to both the eSAFE and the SLED loopback function. When SLED functions are enabled, packets to/from the eSAFE MUST continue to be bridged across the LCI.

5.2.5.2.2 Loopback Protocol

An eCM implementing SLED MUST implement the following loopback protocol:

1. The SLED packet loopback function is attached to the LCI associated with the eSAFE by setting SLED MIB *sledLoopbackInterface* to the eCM's ifIndex number associated with the LCI (per Table 5-1).
2. The SLED MIB object *sledLoopbackPktHdr* is configured with the 42-byte loopback Ethernet packet/IP/UDP headers (14-byte Ethernet header + 20-byte IPv4 header + 8-byte UDP header).
3. As an example, the following loopback header parameters could be used:
 - a) Ethernet MAC source address = eSAFE MAC address
 - b) Ethernet MAC destination address = test station MAC address
 - c) IP source address = eSAFE Management IP address
 - d) IP destination address = test station IP address
 - e) UDP source port number = 7
 - f) UDP destination port number = 7
4. When the SLED MIB object *sledLoopbackInterface* is set to an ifIndex associated with an LCI which supports SLED, *sledLoopbackPktHdr* contains a 42-byte octet string, and *sledLoopbackEnable* is set to 'true', the SLED MUST operate in a loopback mode.
5. When operating in loopback mode, all Ethernet packets forwarded across the indicated LCI by the eCM will be processed as follows⁴⁹:
 - a) If the received Ethernet packet is greater than 1472 octets, the Ethernet packet MUST be split into two fragments according to IP fragmentation scheme as described in [RFC 791], the first consisting of the first 1472 octets of the Ethernet packet and the second containing the remaining octets, resulting in two payloads to that are processed as described below.
 - b) If the received Ethernet packet is less than or equal to 1472 octets, the entire packet MUST be processed as a single payload.
 - c) Each payload generated in step 5a or 5b MUST be prepended with the contents of *sledLoopbackPktHdr*.
 - d) The mutable fields within *sledLoopbackPktHdr* MUST be recomputed. The mutable fields are IP Header Checksum, IP Total Length per [RFC 791], and UDP Checksum, UDP Length per [RFC 768].
 - e) If the Ethernet packet is fragmented as defined in step 5a, the appropriate IP header fields MUST be updated to indicate IP fragmentation. The IP fragmentation header values will differ depending on if this is the first or second fragment being processed (per [RFC 791]). Further, the final 8-bytes of *sledLoopbackPktHdr* (the UDP header) MUST NOT be prepended to the second fragment.

⁴⁹ Note: The eCM MUST remove the Ethernet FCS/CRC32 before encapsulating and processing the packet for loopback. Because the CRC32 may not be present, may be incorrect, and is not relevant to the SLED loopback tests, it is omitted from the packet that is looped back. Note added per eDOCSIS-N-04.0122-2 by kb 7/18/04.

- f) The Ethernet FCS MUST be computed and appended.
 - g) The resulting Ethernet packet MUST be transmitted to the LCI toward the eCM.
6. When the SLED MIB object *sledLoopbackEnable* is set to 'false', the SLED loopback function MUST be disabled.
 7. While the SLED loopback function is enabled, the eCM MUST reject changes to *sledLoopbackInterface* or *sledLoopbackPktHdr*.

Figure 5-11 illustrates the SLED packet loopback encapsulation.⁵⁰

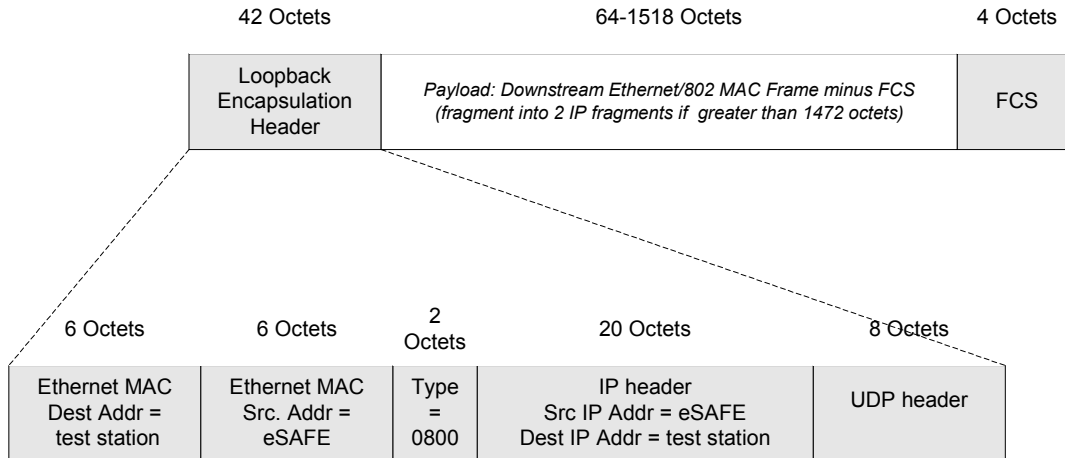

Figure 5-11 - SLED Packet Loopback Encapsulation

Figure 5-12 illustrates an example of the SLED loopback sequence.

5.2.5.2.3 Packet Generation Protocol

An eDOCSIS device implementing SLED MUST implement the following packet generator protocol:

1. The SLED packet generation function is attached to the eCM's LCI associated with the eSAFE by setting SLED MIB *sledPktGenInterface* to the ifIndex number associated with the LCI (per Table 5-1).
2. The SLED MIB object *sledPktGenPayload* is set up to be a complete Ethernet (DIX/802 MAC) packet, including FCS trailer, for transmission across the LCI. The FCS is set to be correct for the packet as specified, and MAY be recalculated by the eCM as required for upstream processing; the SLED is not required to validate the FCS, and a packet with an invalid FCS may be transmitted with a corrected FCS.
3. The SLED MIB objects *sledPktGenRate* and *sledPktGenNumPkts* are set to non-zero values.
4. When *sledPktGenInterface* is set to an ifIndex associated with an LCI which supports SLED, *sledPktGenRate* and *sledPktGenNumPkts* are both set to non-zero values, the SLED Packet Generator MUST start to send generated Ethernet packets to the LCI in within 250 msec after *sledPktGenTrigger* is set to 'start'; the SLED SHOULD start to transmit packets to the LCI as

⁵⁰ Figure modified per eDOCSIS-N-04.0122-2 by kb 7/18/04.

soon as possible in order to minimize the amount of time it takes to run tests that use the SLED Packet Generator.

5. When *sledPktGenTrigger* is set to 'start', the SLED Packet Generator MUST set the SLED MIB *sledPktGenLastTrigger* to the current value of the system MIB *sysUptime*.
6. The packets generated by the SLED Packet Generator MUST be the exact copies of the Ethernet packet specified by the SLED MIB *sledPktGenPayload*. The average rate of generated packets MUST be as specified by the SLED MIB *sledPktGenRate*.
7. The packet generation MUST be continued until the total number of generated packets reaches the limit as specified by the SLED MIB *sledPktGenNumPkts*, unless terminated by setting *sledPktGenTrigger* to 'stop'. If *sledPktGenTrigger* is set to 'stop' while packets are being generated, the SLED SHOULD stop packet generation within 1 second.
8. While the previous sequence of SLED packets is still in progress, the eCM MUST reject changes to *sledPktGenInterface*, *sledPktGenPayload*, *sledPktGenNumPkts* or *sledPktGenRate*.

Refer to Figure 5-12 for an illustration of the SLED packet loopback and generation sequences.

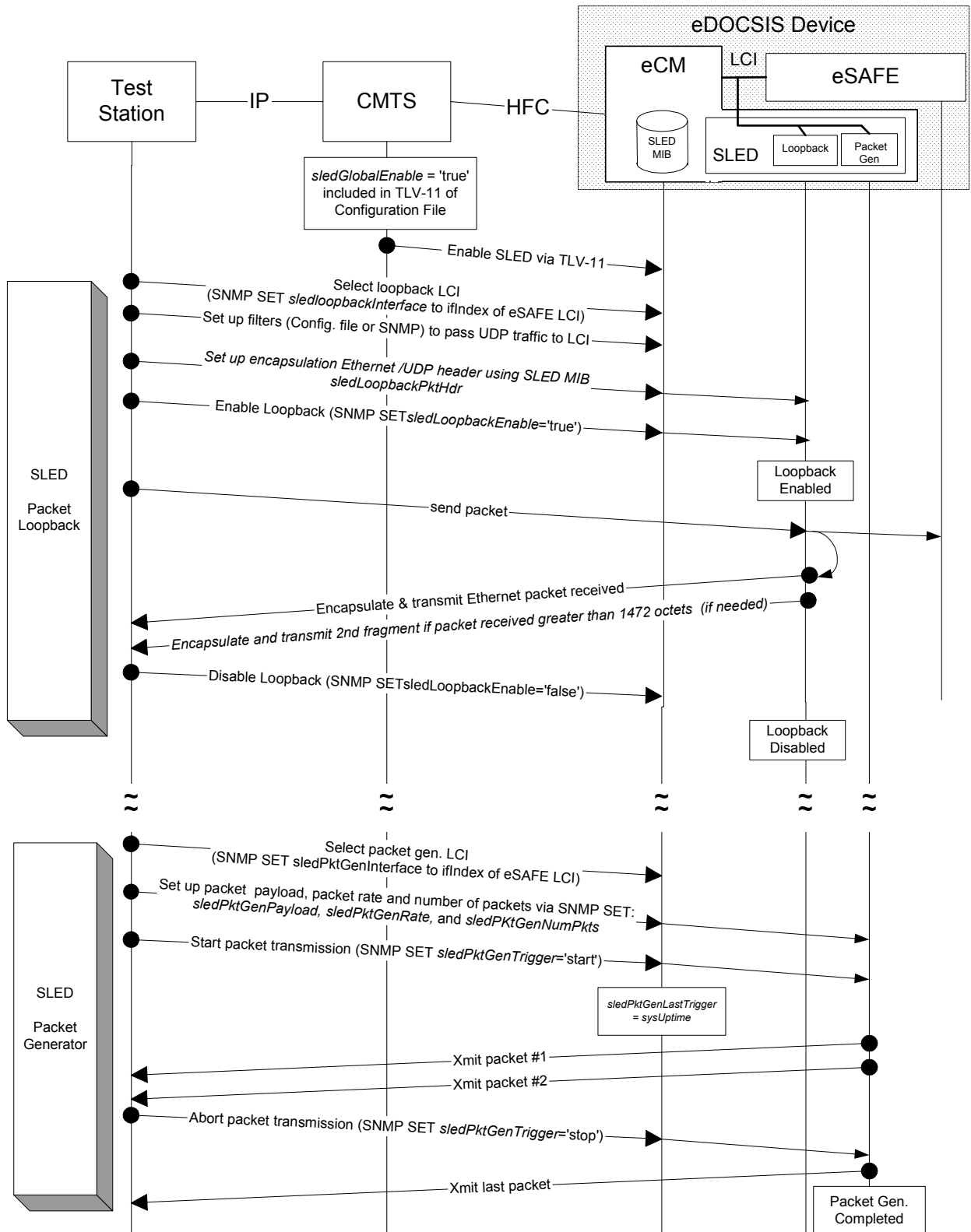

Figure 5-12 - SLED Packet Loopback And Generation Sequences

5.2.6 Firmware Download⁵¹

All eDOCSIS devices MUST support a single secured firmware image download that MUST be used for the entire eDOCSIS device.

With the exception of eDOCSIS devices that contain eSTBs, the download MUST be controlled by the eCM using the DOCSIS Secure Software Download (SSDL) mechanisms as specified in [BPI+].

Firmware download for eDOCSIS devices that contain eSTBs (referred to as a Set-top Device) is defined in the following subsection.

5.2.6.1 Set-top Device Firmware Download

5.2.6.1.1 Firmware Download for OpenCable Advanced Host Set-top Devices

An OpenCable Advanced Host Set-top Device MUST support both or either one of the following firmware download methods:

1. OpenCable Common Download (OCCD) mechanisms as defined in the OpenCable Common Download specification [OC2],
2. DOCSIS Secure Software Download (SSDL) mechanisms as defined in [BPI+].

5.2.6.1.2 OSS Requirements for OCCD

If the Set-top Device employs OCCD firmware download mechanisms, its eCM MUST set the docsDevSwOperStatus to “other” (5) and MUST respond to an attempt to trigger a TFTP upgrade (initiated through SNMP or Configuration File) as follows:

- The SNMP Set or Config File TLV MUST be ignored and the Device MUST remain capable of accepting new software through the non-DOCSIS firmware download mechanism.
- The eCM MUST report the attempt to trigger a TFTP firmware upgrade by logging the appropriate event (via an entry in the docsDevEvTable). The text of this event MUST explicitly indicate that the TFTP upgrade is not applicable for this Set-top Device.
- The docsDevSwOperStatus MUST remain other (5).

If the Set-top Device employs the OCCD firmware download mechanism, then all the download-related requirements as specified in [BPI+] do not apply. Additionally the eCM in this type of Set-top Device MUST support the BPI+ MIB docsBpi2CodeDownloadControl objects with the following constraints (other objects within docsBpi2CodeDownloadControl are as defined within the MIB):

- docsBpi2CodeDownloadStatusCode always reports other (7)
- docsBpi2CodeDownloadStatusString always returns the string “OpenCable Common Download”,

If the Set-top Device employs the OCCD firmware download mechanism, its eCM MUST ignore any firmware upgrade related information in the CM Configuration File and MUST log the appropriate event (via an entry in the docsDevEvTable). The text of this event MUST explicitly indicate that the firmware upgrade related information is not applicable. The message must be sent at level “4 Error”.

⁵¹ Section added per eDOCSIS-N-04.0154-2 by kb 7/18/04

Annex A SLED MIB Definition

```

SLED-MIB DEFINITIONS ::= BEGIN
IMPORTS
    MODULE-IDENTITY,
        Integer32,
        OBJECT-TYPE          FROM SNMPv2-SMI
        TruthValue,
        TimeStamp           FROM SNMPv2-TC
        OBJECT-GROUP,
        MODULE-COMPLIANCE FROM SNMPv2-CONF
    clabProjDocsis          FROM CLAB-DEF-MIB
    InterfaceIndex         FROM IF-MIB
;

sledMib MODULE-IDENTITY
    LAST-UPDATED "200408040000Z" -- August 4, 2004
    ORGANIZATION "CableLabs eDOCSIS Working Group"
    CONTACT-INFO
        "John Eng
        Postal: Cable Television Laboratories, Inc
              858 Coal Creek Circle
              Louisville, CO 80027
              U.S.A.
        Phone: +1 303-661-9100
        Fax:   +1 303-661-9199
        E-mail: mibs@cablelabs.com"
    DESCRIPTION
        "This MIB module provides the management objects necessary
        to configure and invoke the Software Loopback Application
        for eDOCSIS (SLED) functionality."
    REVISION "200408040000Z" -- August 4, 2004
    DESCRIPTION
        "Second version of the eDOCSIS SLED MIB module.
        This revision is published as part of the CableLabs
        eDOCSIS Specification I03.

        MIB edited to match eDOCSIS SLED clarification in ECR.

        Acknowledgement:
        Greg Nakanishi of Motorola, Inc.

        Copyright 1999-2004 Cable Television Laboratories, Inc.
        All rights reserved."

    ::= { clabProjDocsis 17 }

-- Administrative assignments
sledNotifications OBJECT IDENTIFIER ::= { sledMib 0 }
sledMibObjects     OBJECT IDENTIFIER ::= { sledMib 1 }
sledMibNotificationsObjects OBJECT IDENTIFIER ::= { sledMib 2 }
sledMibConformance OBJECT IDENTIFIER ::= { sledMib 3 }

-- Object Groups
sledGlobal OBJECT IDENTIFIER ::= { sledMibObjects 1 }
sledLoopback OBJECT IDENTIFIER ::= { sledMibObjects 2 }
sledPktGen OBJECT IDENTIFIER ::= { sledMibObjects 3 }

--
-- The following group describes the objects that apply to
-- both loopback and packet generator SLED functionality
--

sledGlobalEnable OBJECT-TYPE
    SYNTAX TruthValue
    MAX-ACCESS read-write

```

```

STATUS      current
DESCRIPTION
    "This object allows the SLED functionality to be
    enabled/disabled. This object may only be updated prior to
    device registration. If the device has completed
    registration, any attempt to update the value of this
    object returns 'notWritable'. Prior to registration, if the
    value of this object is set to 'true', the SLED
    functionality is enabled and access to this MIB is allowed.
    Prior to registration, if the value of this object is set
    to 'false', the SLED functionality is disabled and any
    attempt to update other objects in this MIB returns
    'noAccess'."
DEFVAL { false }
 ::= { sledGlobal 1 }

--
-- The following group describes the loopback objects
--

sledLoopbackInterface OBJECT-TYPE
    SYNTAX      InterfaceIndex
    MAX-ACCESS  read-write
    STATUS      current
    DESCRIPTION
        "The index of the logical CPE interface (LCI) that the SLED
        loopback function is attached to. If the index does not
        correspond to a LCI supported by this device, 'wrongValue'
        is returned.
        Any attempt to set this object while sledLoopbackEnable is
        set to 'true' returns 'notWritable'."
    ::= { sledLoopback 1 }

sledLoopbackEnable OBJECT-TYPE
    SYNTAX      TruthValue
    MAX-ACCESS  read-write
    STATUS      current
    DESCRIPTION
        "Setting this object to 'true' enables the loopback
        function. Setting this object to 'false' disables the
        loopback function. When enabled, the eCM removes the
        Ethernet FCS/CRC32 from the original packets. All Ethernet
        packets received by the SLED from the LCI are then processed
        as follows:52

        1. If the received Ethernet packet is greater than 1472
           octets, the Ethernet packet is split into two fragments,
           the first consisting of the first 1472 octets of the
           Ethernet packet and the second containing the remaining
           octets, resulting in two payloads that are processed as
           described below. If the received Ethernet packet is less
           than or equal to 1472 octets, the entire packet will be
           processed as a single payload.
        2. For each payload generated in step 1, the payload is
           appended to the contents of sledLoopbackPktHdr.
        3. The mutable fields within sledLoopbackPktHdr MUST be
           recomputed. The mutable fields are IP Header Checksum, IP
           Total Length, UDP Checksum, and UDP Length.
        4. If the Ethernet packet was fragmented in step 1, the
           appropriate IP header fields (Flags and Fragment Offset)
           are updated to indicate IP fragmentation. These IP
           fragmentation header values will differ depending on
           if this is the first or second fragment being processed.
        5. The Ethernet FCS is computed and appended.
        6. The resulting Ethernet packet is transmitted to the

```

⁵² Paragraph modified per eDOCSIS-N-04.0122-2 by kb 7/18/04.

```

        LCI."
    DEFVAL { false }
    ::= { sledLoopback 2 }

sledLoopbackPktHdr OBJECT-TYPE
    SYNTAX      OCTET STRING (SIZE(42))
    MAX-ACCESS  read-write
    STATUS      current
    DESCRIPTION
        "A properly formatted Ethernet(DIX)+IP+UDP headers for use
        in SLED loopback processing as described in
        sledLoopbackEnable. The object value contains mutable
        fields that are recomputed: the IP Header Checksum,
        IP Total Length, UDP Length, and UDP Checksum. Any attempt
        to set this object while sledLoopbackEnable is set to
        'true' returns 'notWritable'."
    ::= { sledLoopback 3 }
--
-- The following group describes the packet generation objects
--

sledPktGenInterface OBJECT-TYPE
    SYNTAX      InterfaceIndex
    MAX-ACCESS  read-write
    STATUS      current
    DESCRIPTION
        "The index of the logical CPE interface (LCI) that the SLED
        packet generation function is attached to. If the index
        does not correspond to a LCI supported by the device,
        'wrongValue' is returned. Any attempt to set this object
        while sledPktGenTrigger is set to 'start' returns
        'notWritable'."
    ::= { sledPktGen 1 }

sledPktGenPayload OBJECT-TYPE
    SYNTAX      OCTET STRING (SIZE(64..1518))
    MAX-ACCESS  read-write
    STATUS      current
    DESCRIPTION
        "The properly formatted Ethernet packet payload to be
        generated. Any attempt to set this object while
        sledPktGenTrigger is set to 'start' returns
        'notWritable'."
    ::= { sledPktGen 2 }

sledPktGenRate OBJECT-TYPE
    SYNTAX      Unsigned3253
    MAX-ACCESS  read-write
    STATUS      current
    DESCRIPTION
        "The packet rate (in packets per second) that the SLED is
        to transmit the packet specified in the sledPktGenPayload.
        Any attempt to set this object while sledPktGenTrigger is
        set to 'start' returns 'notWritable'."
    DEFVAL { 10 }
    ::= { sledPktGen 3 }

sledPktGenNumPkts OBJECT-TYPE
    SYNTAX      Unsigned3254
    MAX-ACCESS  read-write
    STATUS      current
    DESCRIPTION
        "Number of packets to be generated at the rate specified by

```

⁵³ Changed per eDOCSIS-N-04.0122-2 by kb 7/18/04.

⁵⁴ Changed per eDOCSIS-N-04.0122-2 by kb 7/18/04.

```

        sledPktGenRate. Any attempt to set this object while
        sledPktGenTrigger has been set to 'start' will return
        'notWritable'."
    DEFVAL { 1 }
    ::= { sledPktGen 4 }

sledPktGenTrigger OBJECT-TYPE
    SYNTAX      INTEGER {
        start(1),
        stop(2)
    }
    MAX-ACCESS  read-write
    STATUS      current
    DESCRIPTION
        "This object controls the packet generation. Setting this
        object to 'start' causes the packet generation to begin.
        Reading this object will return 'start' if a packet
        generation is in progress, otherwise it will return 'stop'.
        Setting this object to 'stop' while packet generation is in
        progress aborts the packet generation. Setting this object
        to 'start' while packet generation is in progress,
        'wrongValue' is returned."
    DEFVAL { stop }
    ::= { sledPktGen 5 }

sledPktGenLastTrigger OBJECT-TYPE
    SYNTAX      TimeStamp
    MAX-ACCESS  read-only
    STATUS      current
    DESCRIPTION
        "Value of sysUptime when the packet generation was
        last triggered."
    ::= { sledPktGen 6 }

-- Conformance information *****

sledMibCompliances OBJECT IDENTIFIER ::= { sledMibConformance 1 }
sledMibGroups      OBJECT IDENTIFIER ::= { sledMibConformance 2 }

-- Compliance statements

sledMibCompliance MODULE-COMPLIANCE
    STATUS      current
    DESCRIPTION
        "The compliance statement for SLED."
    MODULE

-- unconditionally mandatory groups

    MANDATORY-GROUPS {
        sledMibBaseGroup
    }

    ::= { sledMibCompliances 1 }

sledMibBaseGroup OBJECT-GROUP
    OBJECTS {
        sledGlobalEnable,
        sledLoopbackInterface,
        sledLoopbackEnable,
        sledLoopbackPktHdr,
        sledPktGenInterface,
        sledPktGenPayload,
        sledPktGenRate,
        sledPktGenNumPkts,
        sledPktGenTrigger,

```

```
        sledPktGenLastTrigger
    }
    STATUS      current
    DESCRIPTION
        "Group of object in SLED MIB."
    ::= { sledMibGroups 1 }

END

55
```

⁵⁵ EDOCS-N-03088 11/17/03 added new figure 5-1 and section 5.2.5 thru Annex A

Annex B eSAFE MIB Definition

An eCM in an eDOCSIS device implementing an embedded CableHome Portal Services logical element (ePS) or/and embedded PacketCable Multimedia Terminal Adapter logical element (eMTA) as an eSAFE MUST implement the following eSAFE MIB.⁵⁶

```
eSAFE-MIB DEFINITIONS ::= BEGIN
IMPORTS
    MODULE-IDENTITY,
    INTEGER,
    OBJECT-TYPE          FROM SNMPv2-SMI  --RFC 2578
    OBJECT-GROUP,
    MODULE-COMPLIANCE   FROM SNMPv2-CONF  -- RFC 2580

    TruthValue,
    DateAndTime,
    Unsigned32          FROM SNMPv2-TC    -- RFC 2579

    SnmpAdminString    FROM SNMP-FRAMEWORK-MIB --RFC 3411

    clabProjDocsis     FROM CLAB-DEF-MIB

;

esafeMib MODULE-IDENTITY
    LAST-UPDATED "200408040000Z" -- August 4, 2004
    ORGANIZATION "CableLabs eDOCSIS Working Group"
    CONTACT-INFO
        "John Eng
        Postal: Cable Television Laboratories, Inc
        858 Coal Creek Circle
        Louisville, CO 80027
        U.S.A.
        Phone: +1 303-661-9100
        Fax: +1 303-661-9199
        E-mail: mibs@cablelabs.com"
    DESCRIPTION
        "This MIB module provides the management objects necessary
        to configure functionality of eSAFE components of a device
        implementing an eDOCSIS compliant cable modem and one or
        more eSAFE elements."
    REVISION "200408040000Z" -- August 4, 2004
    DESCRIPTION
        "Initial version of the eDOCSIS eSAFE MIB module.
        This revision is published as part of the CableLabs
        eDOCSIS Specification I03.

        Copyright 1999-2004 Cable Television Laboratories, Inc.
        All rights reserved."
    ::= { clabProjDocsis 14 }

-- Administrative assignments

-- esafeNotifications OBJECT IDENTIFIER ::= { esafeMib 0 }
esafeMibObjects OBJECT IDENTIFIER ::= { esafeMib 1 }
esafeBase OBJECT IDENTIFIER ::= { esafeMibObjects 1 }
esafePsMibObjects OBJECT IDENTIFIER ::= { esafeMibObjects 2 }
-- Placeholders
-- esafeMtaMibObjects OBJECT IDENTIFIER ::= { esafeMibObjects 3 }
-- esafeStbMibObjects OBJECT IDENTIFIER ::= { esafeMibObjects 4 }

-- Object Groups

--
```

⁵⁶ Annex added by eDOCSIS-N-04.0152-5 by kb

```

-- eSAFE Base Objects
--

esafeProvisioningStatusTable OBJECT-TYPE
    SYNTAX      SEQUENCE OF EsafeProvisioningStatusEntry
    MAX-ACCESS  not-accessible
    STATUS      current
    DESCRIPTION
        "This table contains the current provisioning
         status of each implemented eSAFE, and information
         about the last failure or exception condition in
         the eSAFE provisioning process, if applicable."
    ::= { esafeBase 1 }

esafeProvisioningStatusEntry OBJECT-TYPE
    SYNTAX      EsafeProvisioningStatusEntry
    MAX-ACCESS  not-accessible
    STATUS      current
    DESCRIPTION
        "An entry in this table is created for
         each eSAFE implemented in the eDOCSIS
         compliant device."
    INDEX { ifIndex }
    ::= { esafeProvisioningStatusTable 1 }

EsafeProvisioningStatusEntry ::=SEQUENCE
{
    esafeProvisioningStatusProgress          INTEGER,
    esafeProvisioningStatusFailureFound      TruthValue,
    esafeProvisioningStatusFailureFlow       SnmpAdminString,
    esafeProvisioningStatusFailureEventID    Unsigned32,
    esafeProvisioningStatusFailureErrorText  SnmpAdminString,
    esafeProvisioningStatusLastUpdate       DateAndTime
}

esafeProvisioningStatusProgress OBJECT-TYPE
    SYNTAX      INTEGER {
                notInitiated(1),
                inProgress(2),
                finished(3)
                }
    MAX-ACCESS  read-only
    STATUS      current
    DESCRIPTION
        "The current state of the eSAFE provisioning process.

        notInitiated(1) indicates that the eSAFE has not yet
        begun its provisioning process.

        inProgress(2) indicates that the eSAFE is in the process
        of provisioning, has not yet completed, and has not
        encountered an error or exception condition.

        finished(3) indicates that the eSAFE completed
        its provisioning process. Provisioning success
        or failure information is provided by other
        objects, including
        esafeProvisioningStatusFailureFound and
        cabhPsDevProvState."
    ::= { esafeProvisioningStatusEntry 1 }

esafeProvisioningStatusFailureFound OBJECT-TYPE
    SYNTAX      TruthValue
    MAX-ACCESS  read-only
    STATUS      current
    DESCRIPTION
        "true(1) indicates that the eSAFE encountered

```

an error condition during the provisioning process. An eSAFE could start a looping process from a previous flow step after a failure, therefore this value is retained until the flow step that initially failed eventually passes or is updated with another error condition."

REFERENCE

"PacketCable Provisioning specification, Provisioning Overview section; CableHome specification, Provisioning Processes section."

::={ esafeProvisioningStatusEntry 2 }

esafeProvisioningStatusFailureFlow OBJECT-TYPE

SYNTAX SnmpAdminString

MAX-ACCESS read-only

STATUS current

DESCRIPTION

"If esafeProvisioningStatusFailureFound is true(1) this object contains the label for the provisioning flow step in which the error condition was encountered, otherwise an empty value is reported.

The value of this object corresponds to the provisioning sequence 'Flow Step' designator for the associated eSAFE, as defined in the eSAFE specification. For example, an ePS will report a value like CHPSWMD-1, and an eMTA will report a value such as MTA-1."

REFERENCE

"PacketCable Provisioning specification, Provisioning Overview section; CableHome specification, Provisioning Processes section."

::={ esafeProvisioningStatusEntry 3 }

esafeProvisioningStatusFailureEventID OBJECT-TYPE

SYNTAX Unsigned32 (0..4294967295)

MAX-ACCESS read-only

STATUS current

DESCRIPTION

"If esafeProvisioningStatusFailureFound is true(1) this object contains the eSAFE log error Event Identifier defined in the eSAFE specification, otherwise it returns a value '0'. For an eMTA type eSAFE, this object reports the PacketCable EventID value from the Provisioning Events table, e.g., 65535. For an ePS type eSAFE, this object reports the EventID value from the Defined Events for CableHome table, e.g., 68000100."

REFERENCE

"PacketCable Provisioning specification, Appendix I Provisioning Events; CableHome specification, Appendix II Format and Content for Event, SYSLOG, and SNMP Trap."

::={ esafeProvisioningStatusEntry 4 }

esafeProvisioningStatusFailureErrorText OBJECT-TYPE

SYNTAX SnmpAdminString

MAX-ACCESS read-only

```

STATUS      current
DESCRIPTION
    "If esafeProvisioningStatusFailureFound
    is true(1) this object contains the eSAFE
    log error messages based on the eSAFE
    specification, otherwise it returns an
    empty value. For an eMTA type eSAFE, this
    object reports the value from the
    'Comments' column of the Provisioning
    Events table, e.g., 'DNS Srv request
    has been transmitted and no reply has
    yet been received.' For an ePS type
    eSAFE this object reports the value
    from the 'Event Text' column of the
    Defined Events for CableHome table,
    e.g., 'DHCP Failed - Discover sent,
    no offer received.'"
REFERENCE
    "PacketCable Provisioning specification,
    Appendix I Provisioning Events; CableHome
    specification, Appendix II Format and Content
    for Event, SYSLOG, and SNMP Trap."
::={ esafeProvisioningStatusEntry 5 }

esafeProvisioningStatusLastUpdate OBJECT-TYPE
SYNTAX      DateAndTime
MAX-ACCESS  read-only
STATUS      current
DESCRIPTION
    "The value of the eCM docsDevDateTime when
    this row entry was last updated."
::={ esafeProvisioningStatusEntry 6 }

--
-- Objects that apply to an eCM with an ePS type eSAFE.
--

esafePsCableHomeModeControl OBJECT-TYPE
SYNTAX      INTEGER {
                disabledMode(1),
                provSystem(2)
            }
MAX-ACCESS  read-write
STATUS      current
DESCRIPTION
    "This object provides control over the mode of
    operation of the CableHome ePS eSAFE element
    of the eDOCSIS compliant device.

    When this object is set to disabledMode(1), the
    ePS eSAFE element is instructed to switch to
    CableHome Disabled Mode operation.

    When this object is set to provSystem(2), the ePS
    eSAFE element restarts its provisioning process."
REFERENCE
    "CableHome specifications, CableHome Operational
    Models section."
::= { esafePsMibObjects 1 }

esafePsCableHomeModeStatus OBJECT-TYPE
SYNTAX      INTEGER {
                disabledMode(1),
                dormantCHMode(2),
                cableHomeMode(3)
            }
MAX-ACCESS  read-only

```

```

STATUS      current
DESCRIPTION
    "This object provides visibility to the current
    mode of operation of the CableHome ePS eSAFE
    element of the eDOCSIS compliant device.

    If the value of this object is disabledMode(1), the
    ePS eSAFE element is currently operating in CableHome
    Disabled Mode.

    If the value of this object is dormantCHMode(2), the
    ePS is currently operating in Dormant CableHome Mode.

    If the value of this object is cableHomeMode(3), the ePS
    is currently operating in CableHome mode."
REFERENCE
    "CableHome specification, CableHome Operational Models
    section."
 ::= { esafePsMibObjects 2 }

-- Conformance information *****
esafeMibConformance      OBJECT IDENTIFIER ::= { esafeMib 2 }
esafeMibCompliances      OBJECT IDENTIFIER ::= { esafeMibConformance 1 }
esafeMibGroups           OBJECT IDENTIFIER ::= { esafeMibConformance 2 }

-- Compliance statements

esafeMibBasicCompliance MODULE-COMPLIANCE
    STATUS      current
    DESCRIPTION
        "The compliance statement for eSAFE MIB objects."

MODULE      -- eSAFE-MIB

-- unconditionally mandatory groups

MANDATORY-GROUPS {
    esafeBaseGroup
}

-- conditionally mandatory groups

GROUP esafePsMibGroup
    DESCRIPTION
        "This group is implemented only by eDOCSIS devices
        that implement an embedded Portal Services logical
        element (ePS) compliant with CableLabs
        CableHome specifications."
    ::= { esafeMibCompliances 1 }

-- eSAFE Base Group Declarations

esafeBaseGroup OBJECT-GROUP
    OBJECTS {
        esafeProvisioningStatusProgress,
        esafeProvisioningStatusFailureFound,
        esafeProvisioningStatusFailureFlow,
        esafeProvisioningStatusFailureEventID,
        esafeProvisioningStatusFailureErrorText,
        esafeProvisioningStatusLastUpdate
    }
    STATUS      current
    DESCRIPTION
        "Group of eSAFE Base objects in the eSAFE MIB."
    ::= { esafeMibGroups 1 }

```

```
-- PS MIB Group
esafePsMibGroup OBJECT-GROUP
  OBJECTS {
    esafePsCableHomeModeControl,
    esafePsCableHomeModeStatus
  }
  STATUS      current
  DESCRIPTION
    "Group of embedded PS-specific objects
    in the eSAFE MIB."
  ::= { esafeMibGroups 2 }

END
```

Appendix I Acknowledgements

The inter-disciplinary nature of this specification involves contributions from many individuals. On behalf of CableLabs and its participating member companies, I would like to extend our sincere appreciation to all those have contributed to the development of this specification. Special thanks are given to:

Ralph Brown CableLabs
Eduardo Cardona..... CableLabs
Kevin Leuhrs..... CableLabs
Matt Osman..... CableLabs
Joe Weber..... CableLabs
Greg White..... CableLabs
Margo Dolas..... Broadcom
Gordon Li..... Conexant
Sridhar Sharma..... Imedia
Greg Nakanishi Motorola
Mariano Schain Texas Instruments
Nancy Davoust..... YAS
Doug Jones..... YAS

Special thanks are also given to Liz Weeks of YAS for her skillful editing work making the aggressive release deadlines possible.

John Eng, CableLabs.

Appendix II Revision History

The following Engineering Change Notices have been incorporated in SP-eDOCSIS I02-031117.

ECN	Date Ratified	Summary
EDOCS-N-03084	8/20/03	Incorporate DHCP Option 43 for eDOCSIS.
EDOCS-N-03099	10/29/03	Corrections and Clarifications; alignment of rearranged text with J.eCM submission.
EDOCS-N-03088	10/29/03	Incorporate Software Loopback for eDOCSIS (SLED).

The following Engineering Change Notices have been incorporated in CM-SP-eDOCSIS I03-040804.

ECN	Date Ratified	Summary
eDOCSIS-N-04.0122-2	2/11/04	eDOCSIS SLED clarifications.
eDOCSIS-N-04.0123-2	2/11/04	eDOCSIS DHCP Option 43 clarifications.
eDOCSIS-N-04.0134-2	3/17/04	eDOCSIS DHCP Option 43 suboption 1 clarifications.
eDOCSIS-N-04.0138-1	4/7/04	Reserved DHCP 43 suboptions for eSAFEs.
eDOCSIS-N-04.0150-2	6/30/04	eDOCSIS clarification on the effect of NACO state on eSAFE traffic.
eDOCSIS-N-04.0151-3	6/30/04	Adding eSTB as a new eDOCSIS eSAFE.
eDOCSIS-N-04.0152-5	7/7/04	eSAFE MIB definition for eDOCSIS.
eDOCSIS-N-04.0153-2	6/30/04	eDOCSIS ifIndex filter rules for interfaces to eSAFEs.
eDOCSIS-N-04.0154-2	6/30/04	Modify eDOCSIS firmware download requirements to account for eSTB.
eDOCSIS-N-04.0158-2	7/7/04	Additional RFC 1493 requirements for eDOCSIS devices.
eDOCSIS-N-04.0160-1	7/28/04	Miscellaneous editorial and typo corrections.
eDOCSIS-N-04.0161-1	7/28/04	Remove reference to non-existent eSAFE MIB object.